

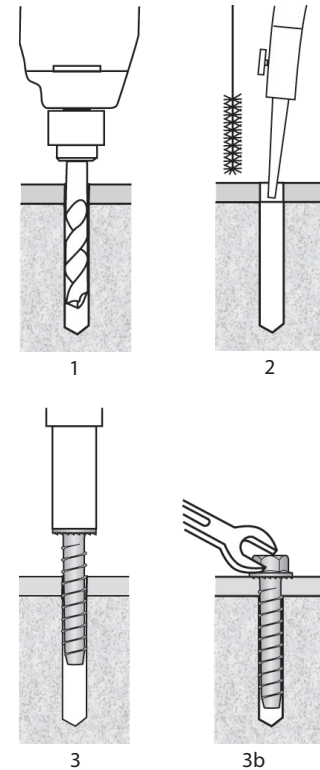

## Installation Instructions

1. Using the proper size carbide bit, drill a pilot hole at least 1/2" deeper than the desired anchor embedment.
2. Clean the hole using a nylon brush and compressed air.
3. **Solid Concrete:** Using an electric impact wrench, or socket wrench, insert anchor through the fixture into hole and tighten anchor until fully seated. If using an electric impact wrench, start on light torque setting to prevent over-torquing or damaging threads.
- 3b. **Concrete Block (CMU)** Using a socket wrench insert anchor into hole and hand tighten anchor until fully seated. Do not use an impact wrench for installation into CMU walls.

NOTE: Always wear safety glasses.



## Performance Data

### Ultimate and Allowable Loads (lbs.) – Normal-Weight Concrete

Anchor Dia. (in.)	Drill Bit Dia. (in.)	Embedment Depth (in.)	Allowable				Ultimate			
			3,000 psi		6,000 psi		3,000 psi		6,000 psi	
			Tension	Shear	Tension	Shear	Tension	Shear	Tension	Shear
1/4	1/4	1-3/16	190	428	258	670	760	1710	1030	2680
		2-1/2	600	443	863	713	2400	1770	3450	2850
3/8	3/8	2	920	890	1063	2060	3680	3560	4250	8240
		3-1/2	2085	2048	2788	3008	8340	8190	11150	12030
1/2	1/2	2	853	1088	1190	2268	3410	4350	4760	9070
		3-1/2	2190	2235	3008	3668	8760	8940	12030	14670
5/8	5/8	2-1/2	873	1190	1173	3163	3490	4760	4690	12650
		3-1/2	2325	2390	3340	5915	9300	9560	13360	23660
3/4	3/4	2-1/2	1078	1570	1760	3535	4310	6280	7040	14140
		5-3/4	3290	3960	6753	7933	13160	15840	27010	31730

Note: The data presented in this table is based on independent laboratory testing at critical anchor spacing and edge distance

\*Tested in accordance with ASTM E488

\*Allowable load capacities are calculated using an applied safety factor of 4:1