

Project :	
Model # :	
Item # :	Qty :
Available W/H :	
Approval :	

## Swing Door Merchandisers

Glass Door Merchandisers  
 Super Deluxe Series

### Model : TGM-23SD-N6

#### FEATURES & BENEFITS

■ **Maintenance-free, Self-Cleaning Condenser (patented) Only at Turbo Air**

The accumulation of dust in the condenser causes the failure or breakdown of refrigerators. Refrigerators run normally until they reach a certain level of accumulation. At some point, when they are over the limit, their performance drops quickly resulting in damage to, or disposal of the stored products in refrigerators. The self-cleaning condenser device keeps the condenser clean and prevents system failure by automatically brushing daily.

■ **Hydrocarbon Refrigerants (R-600a)**

With innovative and eco-friendly technology, Turbo Air brings you hydrocarbon refrigerators designed to meet the new standards of EPA and DOE in 2017. Hydrocarbon refrigerants do not deplete the ozone layer and have very low contribution to the global warming (ODP-0, GWP-3).

■ **Energy conserving fan control**

Utilizing algorithmic air circulation for optimal temperature levels, our innovative fan control system conserves energy by at least 15% and increases compressor life by up to 30%.

■ **Digital temperature control & monitor system**

- Keep food products safe by maintaining constant temperatures.
- Alarms that sound when doors are not sealed shut; protect against food spoilage that originate from cold air leaks.
- Early Warning Alarm program detect issues before malfunction occurs.
- Digital display allows for easy monitoring.
- Programs interpret the condition of refrigeration systems by self-diagnosis.
- Rapid cool-down function (Turbo cooling).
- Automatic evaporator fan motor delays.

■ **Double pane glass doors with Low-E glass**

Energy saving double pane glass doors are equipped with Low-emissivity glass, which reduce outer heat gain and decrease energy consumption. It enhances energy efficiency and minimizes condensation. Lightweight door construction also reduce door maintenance and bushing wear, which in turn facilitates smoother door openings.

■ **Shadow free advertising panel**

Turbo Air is the pioneer in the refrigerator industry on applying special LED Light Guided Panels (LGP). LGP increases panel visibility and eliminates shadows, thus enhances any store atmosphere with eye-catching effects. LED lighting offers 5 times longer lasting life than fluorescents and conserves energy as well.

■ **High-density polyurethane insulation**

The entire cabinet structure is foamed-in-place using high density, CFC free polyurethane insulation.

**LED lighting interior**

■ **Refrigerator holds 33°F ~ 38°F for the best in food preservation**



TGM-23SDB-N6

TGM-23SDCV-N6

TGM-23SDW-N6

**Patented Self-Cleaning Condenser**



This product is equipped with a fine mesh filter to the front of the condenser to catch dust, and a rotating brush that moves up and down daily to remove excess buildup outward and away.



Model	Swing Door	CU./FT.	#of Shelves	HP	AMPS	Crated Weight (lbs.)	L x D* x H† (inches)
TGM-23SD-N6	1	19.4	4	1/4	2.7	325	27 x 30 1/4 x 77

## Model : TGM-23SD-N6

ELECTRICAL DATA	
Voltage	115/60/1
Plug Type	Ⓜ NEMA 5-15P
Full Load Amperes	2.7
Compressor HP	1/4
Cord Length (ft.)	9.8
Refrigerant	R-600a
DIMENSIONAL DATA	
# of Doors	1
Net Capacity (cu. ft.)	19.4
Ext. Length Overall (in.)	27 (685mm)
Ext. Depth Overall (in.)*	30 1/4 (770mm)
Ext. Height Overall (in.)†	77 (1955mm)
Int. Length Overall (in.)	23 (585mm)
Int. Depth Overall (in.)	25 3/4 (655mm)
Int. Height Overall (in.)	60 3/8 (1535mm)
Net Weight (lbs.)	304
Gross Weight (lbs.)	325
# of Shelves	4
Shelf Size (L x D) (in.)	21 3/4 x 22 1/2

Design and specifications subject to change without notice.  
Actual shipping weight may differ due to extra packing materials for product protection.  
\* Depth does not include 2-1/4" (57mm) for door handle.  
† Height does not include 2-1/2" (63mm) for leg height.

■ **WARRANTY : 3 Year Parts and Labor Warranty  
Additional 2 Year Warranty on Compressor**

- **Adjustable PE (polyethylene) coated wire shelves**
- **Door locking system standard**
- **Anti-corrosion coated evaporator**
- **Price tag channel available (optional)**
- **4" dia. casters available (optional)**
- **Three color options available (standard):** white cabinet (W), black cabinet with black color trim (B), or white cabinet with wine color trim (V) (please allow for extra lead time for wine color)

■ **OPTIONAL ACCESSORIES :**

- 4" caster, 1/2" diameter & 13 TPI: G8F6500101 (non-brake), G8F6500201 (w/ brake)
- Additional PE coated wire shelf: 30278R0102
- Price tag channel: P0122K5100 (20-1/4"L)

Ver.20171002

## PLAN VIEW

(unit : inch)

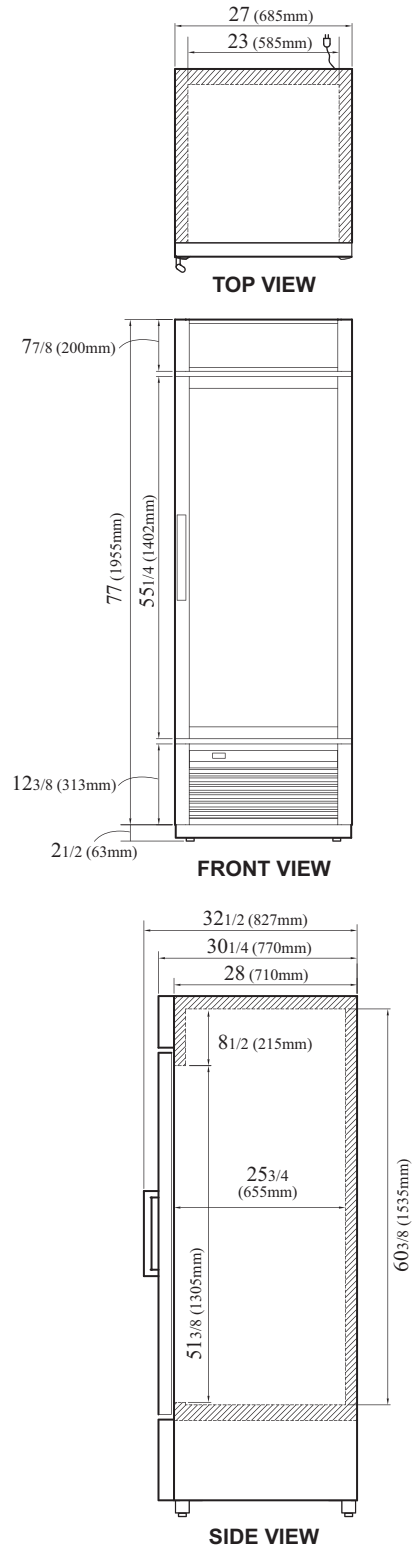

- Turbo Air : 800-627-0032
- GK : 800-500-3519
- Warranty : 800-381-7770
- AC : 888-900-1002