

COUNTER TOP ELECTRIC OVENS



Model P18S

Specifications

Counter top electric deck oven features two Cordierite ceramic hearth baking decks, each 17 3/4" wide (451mm) by 17 1/2" deep (445mm) in a single bake chamber. 3 1/4" decks heights make these oven ideal for pizza, pretzels, flat breads and bakery products baked directly on the hearth deck, pans, baking sheets or screens.

Top and bottom heat is provided by three heavy duty Incoloy steel tubular heating elements total 1800 watts @ 120V or 2850 Watts @ 208-240V. Thermostat ranges from 300° to 650° F (149° to 343° C). The 120V model is recommended for par baked products only.

Exterior front, sides, top and doors is constructed of type 430 stainless steel and measures 22 1/4" wide (572mm) by 17 1/2" tall (445mm). Door handle is constructed of tubular stainless steel.

Baking chamber is fabricated of high heat aluminized steel and welded to form a single unit. Entire oven, including door, is insulated with 1 1/2" (38mm) thick industrial grade insulation.

The P18s features a continuous ring timer with manual shut off. 6' line cord (1830mm). 1-Year limited parts and labor warranty included.

Model – P18S

Standard Features

- 1800 watts @ 120V or 2850 watts @ 208-240V
- 300°-650°F Temperature range (149°-343°C)
- Continuous ring alarm and manual shut-off and volume control
- Two Cordierite hearth decks per oven with 3 1/4" (83mm) deck heights
- All stainless steel exterior
- High heat aluminized steel baking chamber
- 6' (1830mm) line cord
- 4" (120mm) Adjustable legs
- Limited 1-Year parts and labor warranty

Options & Accessories

- Stainless steel stand with or without casters
- Deck scraper brush
- Stacking kit





COUNTER TOP ELECTRIC OVENS

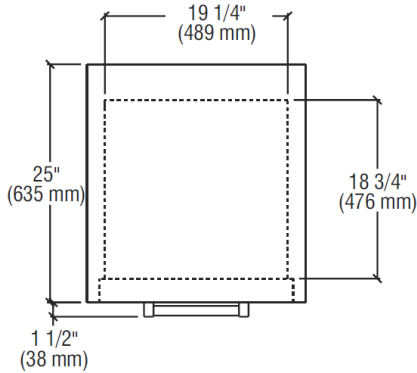

TOP VIEW

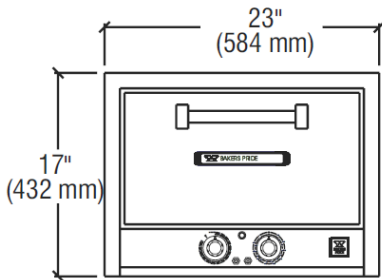

FRONT VIEW

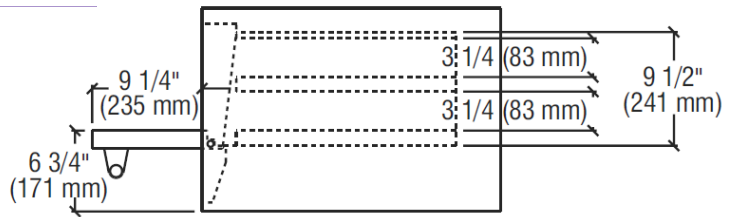

SIDE VIEW

SHIPPING INFORMATION

Model	Shipping Weight		Carton Dimensions				Crate Size			
	Lbs.	Kilos	Width Inches	mm	Depth Inches	mm	Height Inches	mm	Cubic Feet	Cubic Meter
P18S	125	57	27	686	29	737	22	559	10	.28

POWER SUPPLY

Model	WATTS	VOLTAGE	PHASE	AMPS	NEMA Plug #			
					USA	Canada	UK	Europe
P18S	1800	120	1	15	5-15P	5-20P		
P18S	2850	208-240	1	14	6-15P	6-20P	BS1363A	CEE7-VII

Each oven requires a separate electrical connection.

MINIMUM CLEARANCES

	Non-Combustible Construction*		Combustible Construction**	
	Inches	mm	Inches	mm
Left Side	3	76	3	76
Right Side	3	76	3	76
Rear	3	76	3	76

* In European Community Countries and North America. In NON-COMBUSTIBLE locations only.

** In European Community Countries only in COMBUSTIBLE locations. NOT for North America.



5-15P



6-15P



5-20P



6-20P



BS 1363 A



CEE 7-VII

Continuous product improvement is a policy of Bakers Pride Oven Company. Therefore, specifications and design are subject to change without notification.