



BCX-14G
Single or Double Gas
Combination-Oven/Steamer



Shown with optional SmartTouch 2 control and casters

OPTIONS AND ACCESSORIES
(AT ADDITIONAL CHARGE)

- **Legs, stands and casters**
 - 6" (152.4mm) adjustable legs
 - 6" (152.4mm) seismic legs
 - 25" (635mm) adjustable legs
 - Stand mount casters
- **Core Probes**
 - Additional 4" dual sensing probe
 - 6" dual sensing probe
 - 4" fillet probe
- SmartTouch2 control - NEW 7-inch touchscreen stores up to 500 recipes. Includes rack timing, multi-shelf recipes, easy download for recipe writing on your laptop, and HACCP storage capability
- Additional stainless steel wire shelves
- Chicken roasting rack
- Single source water manifold
- Water pressure regulator (1 per section)
- Backflow preventer
- Extended warranty

OPTIONS AND ACCESSORIES
(AT NO CHARGE)

- LP gas
- 208/240 volt



Project _____

Item No. _____

Quantity _____

BCX-14G

All data is shown per oven section, unless otherwise indicated.

Refer to operator manual specification chart for listed model names.

EXTERIOR CONSTRUCTION

- Stainless steel top, front, sides and back
- Dual pane tempered viewing window with hinged inner glass for easy cleaning
- Door mounted condensate trough
- Top and bottom mount, easily adjustable door hinges
- Pivot out user interface panel for service access

INTERIOR CONSTRUCTION

- Fully welded stainless steel frame
- Fully insulated cooking chamber
- Fixed drain bottom center of cavity
- Easily removable stainless steel side rails
- Coved corner liner for ease of cleaning

OPERATION

- Standard control with function selection for hot air, humidity and cool down plus ability to store 100 recipes
- Steam on demand feature
- Core probe cook and hold capabilities with 4" removeable core temperature probe
- USB connection for recipe upload or download
- Thermostat control to 500F
- Multiple speed reversing fan for even bake
- Dual stage door latch to vent steam before fully opening door
- Cavity vent control provides ability to release steam at the push of a switch
- Integral door switch
- Open vented system. Condenses steam and drains away by-products of the cooking process, eliminates flavor transfer
- Self contained, self-flushing steam generator separate from cooking compartment for instant steam recovery when switching modes
- Control prompts user to delime when steam generator requires delimiting

CAPACITY

- Fourteen 12" x 20" x 2-1/2" deep pans at 3-1/4" spacing
- Seven 18" x 26" deep pans at 3-1/4" spacing

STANDARD FEATURES

- Five (5) stainless steel wire shelves per section (capacity for 7)
- Hinged pressure panel for cleanability
- Halogen lights for superior cavity illumination
- Retractable hose reel (excluding top sections)
- Stacking kit and casters for double stack ovens
- Semi-auto delime system
- Delimiting bottle and pump assembly
- Pressure spray bottle for oven cleaning
- 4" core temperature probe
- Floor stand with rack supports
- Start-up inspection service by factory authorized service agent
- One year parts and labor oven warranty*

* For all international markets, contact your local distributor.



BCX-14G



APPROVAL/STAMP

DIMENSIONS ARE IN INCHES (MM)

- ⚡ Electric ⚙ Gas Ⓜ Drain
- ⚡ Unfiltered Water - Condensate, cold only
- ⚡ Filtered Water - Boiler, hot or cold

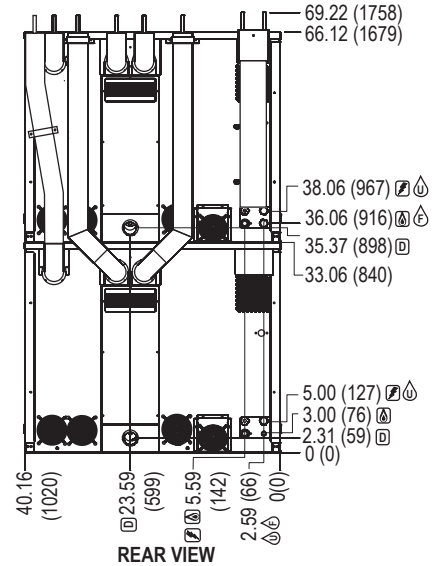
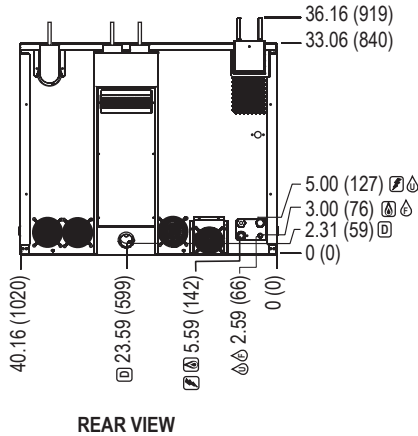
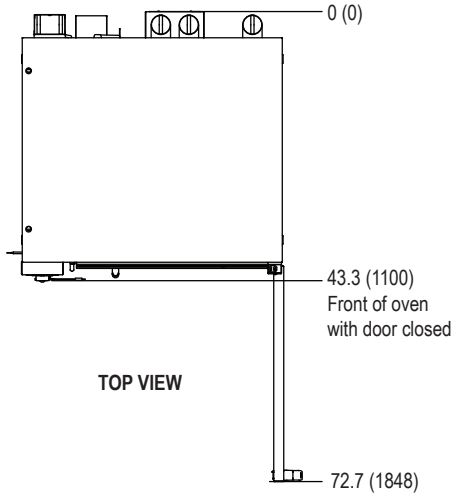

SHORT FORM SPECIFICATIONS: Provide Blodgett Combi model BCX-14G single, gas combination-oven/steamer. Unit shall have the ability to cook with pressureless steam (212F), hot air, or combination of steam and hot air (with an operating range 140F to 500F), vario-steaming (operating range 140F to 212F), low temperature cooking and holding, rethermalizing, cool down mode and our Exclusive Steam on Demand steam injection system. Unit shall have programmable manual control capable of storing 100 recipes and USB connection. Oven capacity to accept 7ea 18x26 bake pans or 14ea 12x20x2.5" full size steam table pans with 3-1/4" spacing. Front access service user interface control panel and service diagnosis system. Unit shall be constructed with a fully welded stainless steel frame. Cooking chamber shall be constructed with 304 series with bright-annealed stainless steel finish and covered corners. Retractable hose reel (excluding top sections) to include front water shut off valve. Unit shall include a four speed, bi-directional fan with vent switch to control humidity in the cooking chamber. Dual pane thermal glass window with 180 degree door swing, two-step safety door-latch with adjustable door hinges, door mounted drip pan. Unit to include a detachable 4" core temperature probe and halogen lights. Supply with exclusive time to delime indicator with adjustable settings of 30, 60 or 90 hours of run time, semi-automatic delimiting system. Where applicable, quantities in this spec are doubled for stacked units. A start-up inspection service will be performed by our factory-authorized agent at no cost to the operator. One-year parts and labor warranty, standard.

DIMENSIONS:

Floor space: 42.30" x 40.19" (1074 x 1021mm)
 Unit Height:
 Single 36.16" (919mm)
 Double 69.22" (1758mm) without casters/legs

Additional Height:

Low profile caster for stacked units 4" (101.6mm)
 6" adjustable legs 6.88" - 8" (174.6-203.2mm)
 6" adjustable seismic legs 6.63" - 8" (168.3-203.2mm)
 25" adjustable legs 25.25" - 26.38" (641.4-670mm)
 Stand w/rack supports 22.5" - 23.63" (571.5-600.1mm)
 Stand w/rack supports on casters 22.63" (574.7mm)

OVEN CLEARANCES:

Right Side 1" (25.4mm)
 Left Side 6" (152.4mm)
 Rear 6" (152.4mm)

MINIMUM ENTRY CLEARANCE:

Uncrated 33" (838mm) after adjustment of flue brackets
 Crated 42" (1066.8mm)

POWER SUPPLY (per section):

Standard 115VAC, 12 amp, Nema 5-20R dedicated receptacle
 Option 208-240VAC, 6 amp, Nema 6-15 dedicated receptacle
 Export Export voltages available on request
 Blodgett recommends a Pass & Seymour, model 2095, GFCI for this oven model due to the use of a variable frequency drive.

NOTE: The company reserves the right to make substitutions of components without prior notice

Printed in U.S.A.

GAS SUPPLY (per section):

3/4" NPT
Inlet Pressure:
 Natural - 7.0" W.C. static to unit Propane - 14.0" W.C. static to unit

Maximum Input:

Hot Air - 65,000 BTU/hr Boiler - 50,000 BTU/hr Total Input - 115,000 BTU/hr

WATER SUPPLY & DRAIN:

Good quality water feed is the responsibility of the owner. Water quality must be within the following general guidelines.

TDS: 40-125 ppm Hardness: 35-100 ppm pH: 7.0 - 8.5
 Silica: <13 ppm Chlorides: <25 ppm Chlorine: <0.2 ppm
 Chloramine: <0.2 ppm

The best defense against poor water quality is a water treatment system designed to meet your water quality conditions. Blodgett offers optional systems from Optipure.

Pressure: 40(min)-50(max) PSI
 Connections: 2" drain connection - max. drain temperature 140°F (60°C)
 3/4" garden hose cold water

The drain piping must consist of temperature resistant material, greater than 160°F, and be of adequate diameter not to cause flow restriction. Improper materials may deform and cause restrictions, thus affecting performance.

Appliance is to be installed with backflow protection in accordance with federal, state or local codes.

SHIPPING INFORMATION:

Approx. Weight:

Single - 645 lbs. (293 kg) Double - 1320 lbs. (599 kg) Stand w/guides - 140 lbs. (64 kg)

Crate sizes (per section): 44.5" H x 42" W x 54.25" D (1130 x 1067 x 1378mm)

NOTE: FOR COMMERCIAL USE ONLY

P/N 39453 Rev AA (7/17)