



STAINLESS STEEL UTILITY CARTS

Item #: _____ Qty #: _____
 Model #: _____
 Project #: _____



150 lb. Capacity

FEATURES:

- Knock Down Unit
- 4" Swivel Casters
- Sound dampening pads affixed to shelving bottom
- Adjustable shelves furnished with 1 1/4" x 1" square edge with 1/2" return on four sides

CONSTRUCTION:

- Unit assembles using tapered split sleeves
- Set of four 4" swivel casters includes two casters with brakes and 4 donut bumpers

MATERIAL:

SHELVES: Heavy Gauge Stainless Steel

TUBING: Chrome Posts

Model #	A	Length	Width	Wt.
UC-3-1827	27"	34 1/2"	18"	27 lbs.
UC-3-2433	33"	40 1/2"	24"	35 lbs.



700 Capacity

FEATURES:

- Welded Set-Up Unit
- Two 3 Sided Shelves for Ease of Loading Trays
- Padded Push Handle with Bumpers
- Upper Edge Bumpers
- Two 5" Swivel Stem Casters in Front,
- Two 8" Fixed Casters in Rear

MATERIAL:

SHELVES: 16 Gauge Stainless Steel

FRAME: 12 Gauge Uprights

Model #	Length	Width	Height	Shelf Spacing	Wt.
UCS-1	39 1/2"	35 1/2"	21"	19 1/2"	78 lbs.



Customer Service Available To Assist You **1-800-645-3166** 8:30 am - 8:00 pm E.S.T.

For Orders & Customer Service:

Email: customer@advancetabco.com or Fax: 631-242-6900

For Smart Fabrication™ Quotes:

Email: smartfab@advancetabco.com or Fax: 631-586-2933

DETAILS and SPECIFICATIONS

TOL ± .500"

ALL DIMENSIONS ARE TYPICAL

UC-3 Series

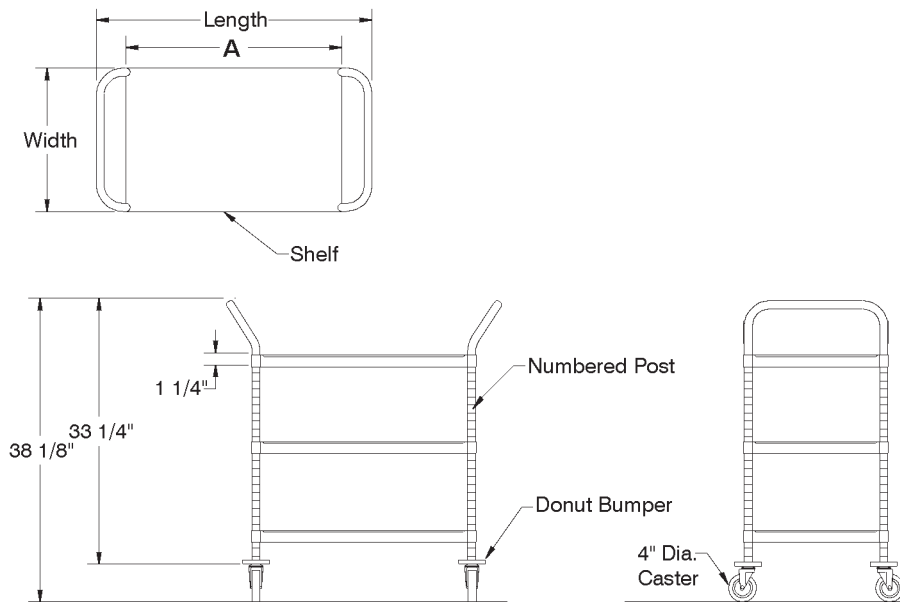

UCS-1

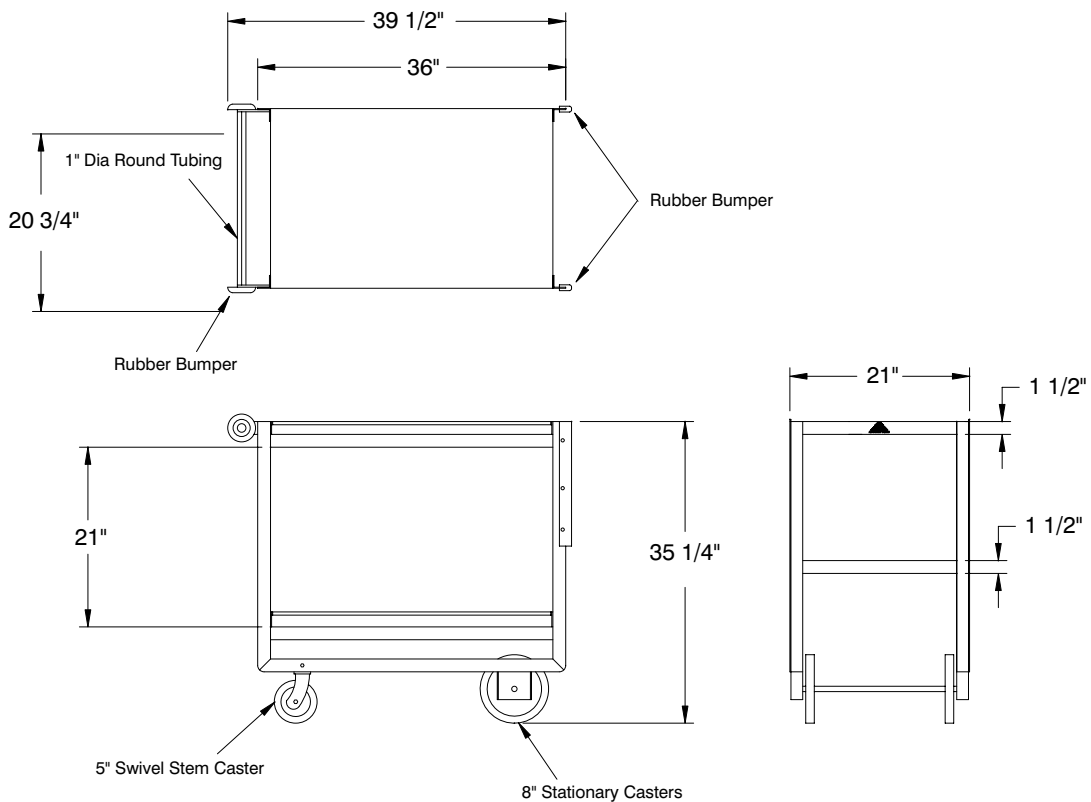

700 lbs.



REF-O

200 Heartland Boulevard, Edgewood, NY 11717-8380

ADVANCE TABCO is constantly engaged in a program of improving our products. Therefore, we reserve the right to change specifications without prior notice.

© ADVANCE TABCO, JANUARY 2017