

GENERAL INFORMATION

Project Name: _____
Item: _____
Quantity: _____
Model: CP-120 _____
Length: _____

GENERAL SPECIFICATION

Materials

- 18-Gauge Brushed Finish Type 304 Stainless Interior Pan Liner
- 16-Gauge Brushed Finish Type 304 Stainless Exterior
- Pressure Foamed Insulation
- 1/2" Drain with Ball Valve and 60" Clear PVC Drain Tube

Construction

- NSF Standard 2 Construction
- Coved Corner Pan

CP-120

Counter-Top Marche Style Cold Pan

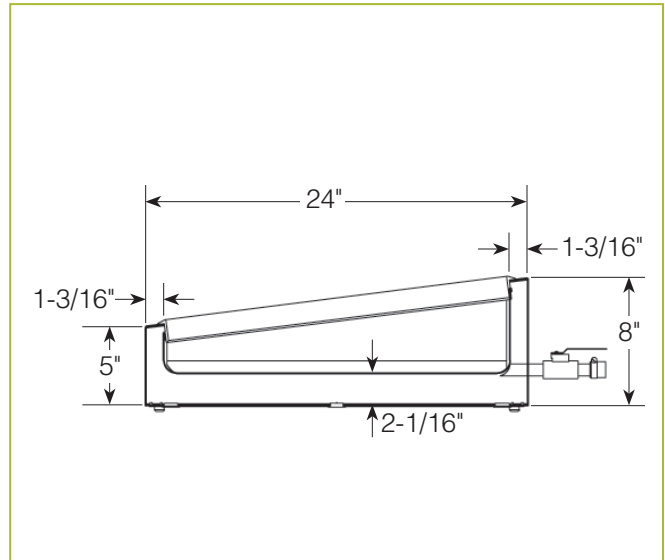

EXTERIOR MATERIAL OPTIONS

- Hardwood Veneer: Type _____
- Hardwood (Solid): Type _____
- Plastic Laminate: Color _____
- Solid Surface: Color _____

EXTERIOR FINISH OPTIONS

- Sand Blast
- Mirror Polished
- Stain: Type _____
- Powder Coat: Color _____

MODEL	CP-120-2424	CP-120-2430	CP-120-2436	CP-120-2442	CP-120-2448
Length	24"	30"	36"	42"	48"
Width	24"	24"	24"	24"	24"
Net Weight	40 lbs.	47 lbs.	55 lbs.	64 lbs.	73 lbs.
Shipping Weight	57 lbs.	63 lbs.	74 lbs.	85 lbs.	97 lbs.
Cubes	7	7	8	9	11

* Approval Drawings Required

Printed in the U.S.A. (April 2017) BSI, LLC
 Specifications subject to change without notice.

Rv. 9