

Job: \_\_\_\_\_

Item: \_\_\_\_\_

Quantity: \_\_\_\_\_

**New Age Industrial Corp., Inc.**

PO Box 520 • 16788 US Hwy 36 • Norton, Kansas 67654

Phone: 800-255-0104 • Fax: (877)-877-7687 • [www.NewAgeIndustrial.com](http://www.NewAgeIndustrial.com)

## #96856 - FOLDING UTILITY CART

• **Effortless Stocking Capability**

- Ideal for transporting heavy loads from the back room to the floor area or cooler.
- Big enough to stock a complete area with one trip!

• **Completely Portable**

- Six wheel design allows the unit to turn on a dime.
- Equipped with four 5" platform type swivel casters and two 6" x 2" platform type rigid casters.

• **Maximum Storage Space**

- Stores upright (on-end) to maximize available storage space.

• **Material**

- Framework is constructed out of 1½" x 1½" x .070" wall tubing.

- Handle is constructed out of 1½" diameter pipe and is reinforced by ½" x 1" x .070" wall tubing.

• **Guaranteed Maintenance Free**

- Five-Year Guarantee against material defects and workmanship.
- Lifetime Guarantee against rust and corrosion.



**#96856**

Model No	Size Unfolded	Size Folded	Wt. Cap.	Product Wt.	Ship Wt.
96856	16" x 64" x 64¾"	16" x 14" x 64¾"	1500#	61#	74#

Four 5" x 1¼" polyurethane, platform type swivel casters (#C450) and two 6" x 2" polyurethane, platform type rigid casters (#C518).

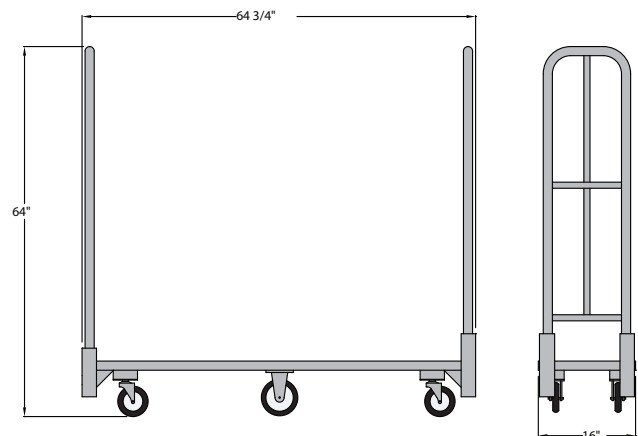

*This information is for general sales and engineering use only. New Age Industrial reserves the right to modify or make changes at any time without notice to materials and specifications.*

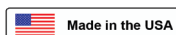

Distributed by: