

## V-Series 100 Qt. Mixer

The kitchen workhorse, for a wide range of heavy-duty mixing applications.



### MODELS

- V100PL** 100 qt. Power Lift Mixer

### STANDARD FEATURES

- Stainless steel top cover, planetary cover, bayonet shaft, bowl guard and legs
- IP32 rated
- Powerful 4 HP motor with variable speed drive and agitator speed range from 47 RPMs to 257 RPMs
- No bowl adapters required for down-sizing bowls
- Front-mounted controls with 90-minute digital timer, power bowl lift and emergency stop
- Durable powder coated finish on legs and outer surfaces not constructed of stainless steel
- High torque transmission
- Permanently lubricated planetary head & attachment hub case
- Bowl scraper bracket affixes to planetary head
- Grease lubricated, anti-friction ball bearings
- Patent-pending interlock prevents operation if guard is opened or bowl is lowered
- Overload protection and no volt release
- Non-skid rubber feet
- 6 foot cord
- ETL and NSF listed
- Made in Denmark

### STANDARD ACCESSORIES

- Stainless steel bowl
- Stainless steel flat beater
- Stainless steel wire whip
- Stainless steel dough hook

### WARRANTY

- Two-year parts and labor limited warranty

### OPTIONAL ACCESSORIES/ATTACHMENTS

- 40 qt. bowl and attachments
- 60 qt. bowl and attachments
- Bowl scraper - 40 qt., 60 qt. or 100 qt. options
- Bowl Truck
- Stainless steel model

*To select options see back*



ETL listed  
Conforms to UL Std 763  
Certified to CSA Std C22,2 No. 195

Approved by: \_\_\_\_\_

Date: \_\_\_\_\_

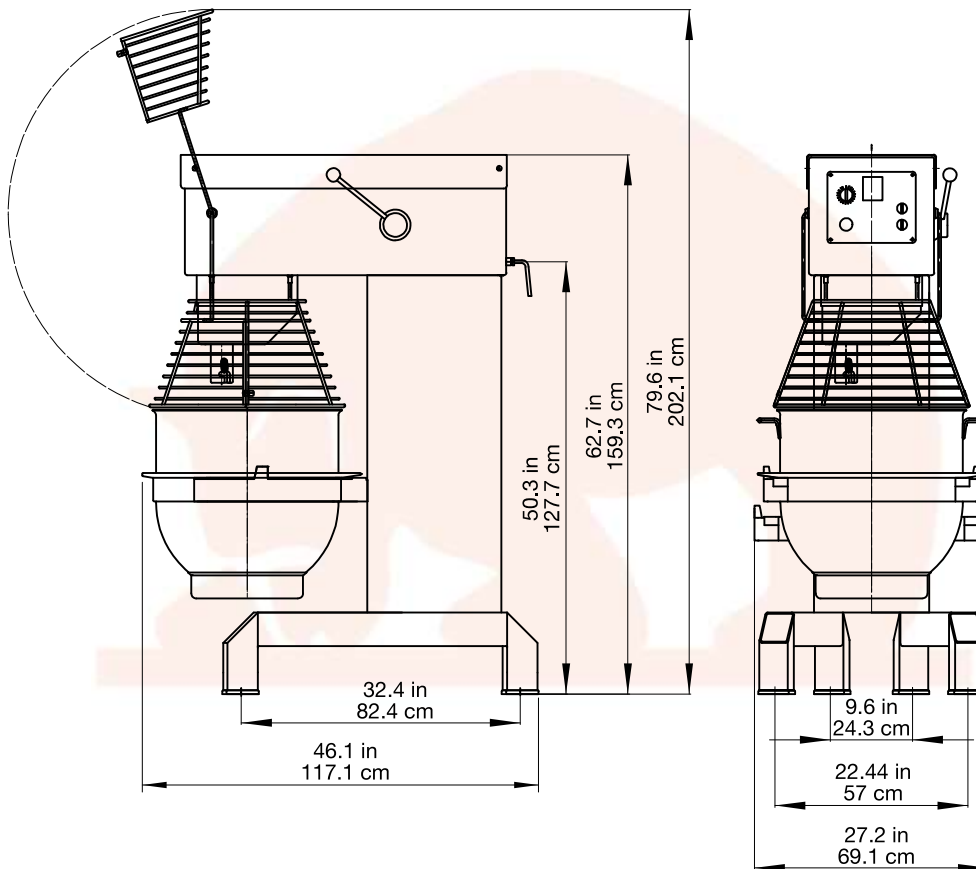

## SPECIFICATIONS

| Model  | Motor | Volts    | Amp | Plug Type | Mixing Speeds | Hub Speeds | IP Rating |
|--------|-------|----------|-----|-----------|---------------|------------|-----------|
| V100PL | 4 HP  | 208/60/3 | 13  | --        | 47 - 257 RPMs | N/A        | IP32      |

Delivered without plug. Specify voltage when ordering.

## DIMENSIONS | SHIPPING INFORMATION

Reinforced carton for shipping. This product ships on a pallet. See dimensions below.

| Model  | Overall Dimensions   | Net Wt.              | Shipping Dimensions  | Ship Wt.                | Freight Class   |
|--------|--|----------------------|--|-------------------------|-----------------|
| V100PL | 29" W x 44.5" D x 63" H<br>(73.66 cm x 113.03 cm x 160 cm) | 870 lbs.<br>(395 kg) | 33" W x 49" D x 78" H<br>(83.82 cm x 124.4 cm x 198.12 cm) | 981 lbs.<br>(444.97 kg) | 85<br>73 CU ft. |

## OPTIONAL/ADDITIONAL ACCESSORIES

- VTRUCK-100 Bowl truck
- VBOWL40-100 40 qt. bowl
- VBOWL60-100 60 qt. bowl
- VSCRIP-40 40 qt. scraper
- VSCRIP-60 60 qt. scraper
- VSCRIP-100 100 qt. scraper
- VHOOK40-100 40 qt. hook
- VHOOK60-100 60 qt. hook
- VBEAT40-100 40 qt. beater
- VBEAT60-100 60 qt. beater
- VWHIP40-100 40 qt. standard wire whip
- VWHIP60-100 60 qt. standard wire whip
- VWINGWHIP100 100 qt. wire wing whip
- VHDWHIP-100 100 qt. heavy-duty wire whip

| Product              | Attachment    | V100PL   |
|----------------------|---------------|----------|
| Bread Dough (65% AR) | Hook          | 155 lbs. |
| Pizza Dough (50% AR) | Hook          | 135 lbs. |
| Mashed Potatoes      | Whip / Beater | 76 lbs.  |
| Whipped Cream        | Whip          | 20 qts.  |
| Pancake Batter       | Whip / Beater | 44 qts.  |
| Cookie Dough         | Beater / Hook | 105 lbs. |

Heavy-duty 100 qt. mixer with 4 HP motor and variable speed drive with agitator speed range from 47 to 257 RPMs. Stainless steel top cover, bayonet shaft and bowl guard. Non-stainless steel surfaces powder coated finish. Front-mounted controls with power bowl lift and 90-minute digital timer. Permanently lubricated planetary head and attachment hub case. 6 ft. cord. Mixer is IP32 rated with ETL and NSF certification. Two-year parts and labor limited warranty.