

# PIZZA PREPARATION TABLE

## Model: CPA118

### 118" Pizza Preparation Refrigerator with Solid Doors

Heavy gauge #300 Series stainless steel top, stainless steel front and end panels, galvanized steel rear and grill and aluminum interior.  
**Certified under NSF-7 to maintain temperatures in 86°F ambient and designed to maintain NSF-7 temperatures in 100°F ambient.**



#### Options and Accessories

(upcharge and lead times may apply)

Stainless steel interior	Stainless steel pan slides
Stainless steel back	Wire rod garnish rack
Stainless steel shelves	Vision panel lid
Add'l epoxy-coated steel shelves	Door locks
Drawers in lieu of full doors	Adjustable legs
Drawer in lieu of half door above the condensing unit*	Front breathing
Condensing unit left or right	Special electrical requirements (consult factory)
Automatic, electric condensate evaporator	

\*Drawer section above condensing unit holds (1) 12 x 20 x 6 pan

**Continental**  
 Refrigerator

Toll-Free: 800-523-7138  
 Phone: 215-244-1400  
 Fax: 215-244-9579

539 Dunksferry Road  
 Bensalem, PA 19020  
[www.continentalrefrigerator.com](http://www.continentalrefrigerator.com)

Project Name:

Model Specified:

Location:

Item No:

Quantity:

AIA #:

SIS #:

#### Standard Model Features

##### REFRIGERATION SYSTEM

Performance-rated refrigeration system

Environmentally-safe R-134a refrigerant

Unique forced air design utilizes fans (approx. every 12") across the entire back of unit for even distribution of cold

Automatic, energy saving, non-electric condensate evaporator

Non-corrosive, plasticized fin evaporator coil

Easily serviceable, slide-out condensing unit

##### CABINET ARCHITECTURE

2" non-CFC polyurethane foam insulation

Spring loaded, self closing doors

Magnetic snap-in door gaskets

Heavy-duty, epoxy-coated steel shelves

19" deep, full length nylon cutting board

Refrigerated section with door above the condensing unit

Insulated lids

5" casters

##### MODEL FEATURES

Electronic controller w/digital display & hi-low alarm

Ergonomically-friendly raised angle rail

Expansion valve for quick recovery

Built-in, off cycle defrost timer

Field rehingeable doors

**NOTE:** CPA models come standard with a door over the condensing unit. A drawer over the condensing unit is an option.

APPROVAL:

## Model Specifications

### DIMENSIONAL DATA

Net Capacity (cu. ft.)	44 (1246 cu l)
Width, Overall (in.)	118 (2997 mm)
Depth, Overall (in.) (incl. handles & bumpers)	36 7/8 (937 mm)
Height, Overall (in.) (incl. 5" casters)	39 7/16 (1002 mm)
Depth, Cutting Board (in.)	19 (483 mm)
Pan Capacity (pans supplied by others)	(16) 1/3
Shelf Area (sq. ft.)	18.4 (1.7 sq m)
No. of Shelves	4
No. of Full Doors	4
No. of Half Doors	1
Interior Depth (in.)	27 3/8 (695 mm)
Interior Height (in.)	26 (660 mm)
Interior Height (in.) (above condenser)	12 1/2 (318 mm)
Interior Width (in.)	114 (2896 mm)

### REFRIGERANT DATA

Condensing Unit Size (H.P.)	3/4
Capacity (BTU/Hr)*	5600

### ELECTRICAL DATA

Voltage (int'l)	115/60/1 (220/50/1)
Fans	8
Total Amps (int'l)	16.6 (12.6)
10 ft. Cord/Plug [attached] (int'l)	Yes (No)

### SHIPPING DATA

Weight (lbs.)	725 (1111 kg)
Height - Crated (in.)	43 3/4 (1111 mm)
Width - Crated (in.)	120 (3048 mm)
Depth - Crated (in.)	47 (1194 mm)

\* Rating @ +25°F evaporator, 90°F ambient

Figures in parentheses reflect metric equivalents rounded to the nearest whole unit.



Equipped with one NEMA-5-20P Plug  
(varies by country)

## Model Plan Views

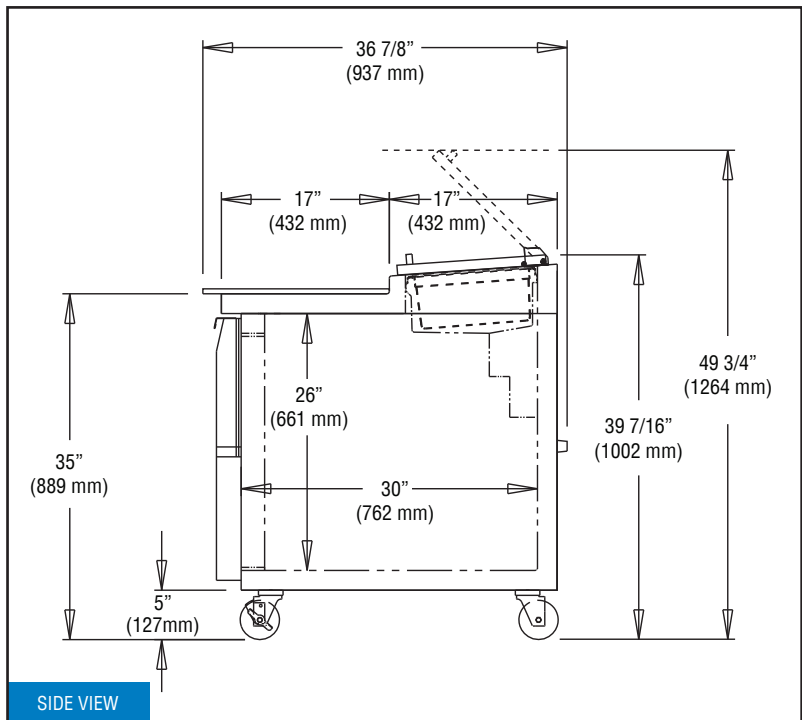
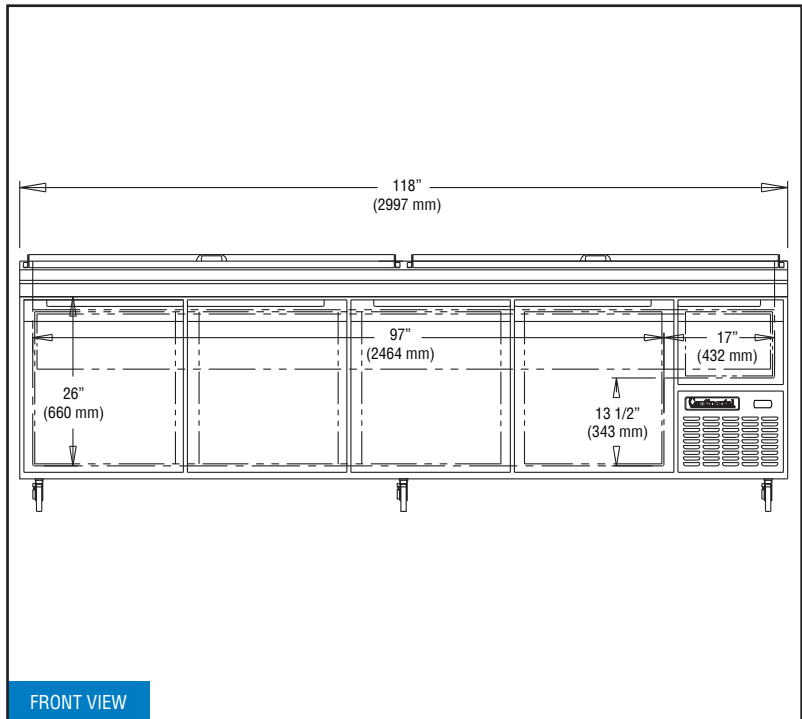

**IMPORTANT NOTE:** If the cabinet is located directly against a wall, a minimum clearance of 3" is required on sides, front and rear.

**Continental**  
Refrigerator

Toll-Free: 800-523-7138  
Phone: 215-244-1400  
Fax: 215-244-9579

539 Dunkserry Road  
Bensalem, PA 19020  
[www.continentalrefrigerator.com](http://www.continentalrefrigerator.com)

Due to our continued efforts in developing innovative products, specifications subject to change without notice.



MADE IN THE U.S.A.

© Copyright 2017. Continental Refrigerator.  
A Division of National Refrigeration & Air Conditioning Products, Inc.