

VC-GPSWM



GPS Antenna Wall Mount, 1.05 in OD x 48 in

Product Classification

Product Type Wall mount kit

Dimensions

Height 254.0 mm | 10.0 in
Length 1219.2 mm | 48.0 in
Pipe Outer Diameter 26.7 mm | 1.1 in
Weight 4.8 kg | 10.5 lb
Width 254.0 mm | 10.0 in

Environmental Specifications

Wind Rating For Specifications, please contact steelproducts@commscope.com or call 800-255-1479

General Specifications

Mounting Walls
Includes Mount
Material Type Hot dip galvanized steel
Package Quantity 1
Pipe Length 1219.2 mm | 48.0 in
Pipe, quantity 1

Outline Drawing

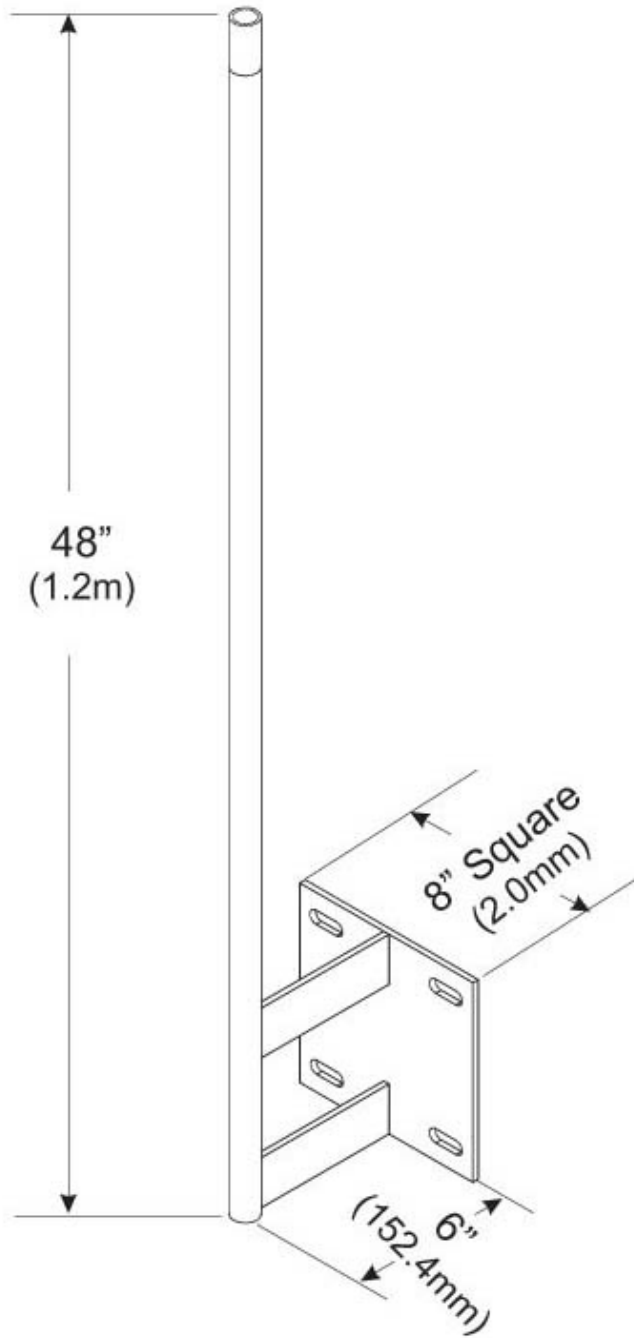

Regulatory Compliance/Certifications

VC-GPSWM

Agency

ISO 9001:2015

Classification

Designed, manufactured and/or distributed under this quality management system

*** Footnotes****Wind Rating**

BWS—Base Wind Speed; FBC—Florida Building Code