

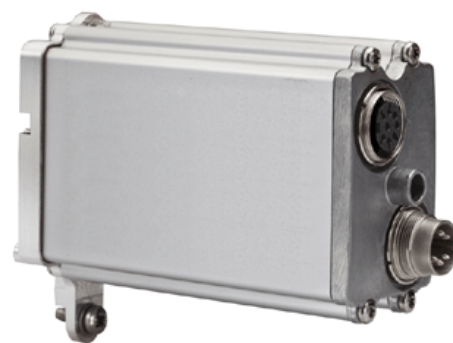

- The ACU-A20-S Antenna Control Unit (ACU) is part of the complete RFS AISG compliant Optimizer RT® remote antenna control system. The ACU-A20-S is a direct replacement for the ACU-A20-N. With its smaller and more ergonomic form factor, installation is easier and more cost-effective especially when using multi-band antennas with several ACUs.
- The Optimizer RT® remote antenna control system permits accurate antenna tilt operations to be conducted - without riggers or crane equipment - either from the tower base or the network management center.

FEATURES / BENEFITS

- Compliant with AISG standards
- Enables remote electrical tilt of antennas
- Direct replacement for the ACU-A20-N in a smaller size
- Travel time <30 seconds typically



ACU-A20-S

Technical features

GENERAL SPECIFICATIONS

Product Type		Antenna Control Unit
Configuration		Optimizer RT® Antenna Control Unit (ACU) for AISG2.0
Applications		Wireless Communication
Firmware		Remotely upgradeable (including AISG2.0)
Standards		RoHS Compliant and CE Compliant: Directive 1999/5/EC Radio Equipment and Telecommunication Terminal Equipment and the mutual recognition of their conformity, Directive 2006/95/EC Electrical Equipment designed for use within certain voltage Limits, Directive 2002/95/EC for the Restriction on the use of Hazardous Substances (RoHS) in electrical and electronic equipment.

MECHANICAL SPECIFICATIONS

Connectors		AISG DIN female & AISG DIN male, ready for daisy-chaining
Temperature Range	°C (°F)	-40 to 70 (-40 to 158)
Mounting		Directly onto antenna
Dimensions, H x W x D	mm (in)	103 x 41 x 88 (4 x 1.6 x 3.5)
Housing		Aluminium, with extruded body and molded end caps
Mounting Screw		M4
Motor Type		Stepper
Continuous Torque	Nm	0.15
Angular Resolution for Shaft Turn		Less than 0.5 turn (< 0.2 degree as tilt angle)
Lifetime		36,000 antenna adjustments

TESTING AND ENVIRONMENTAL

Ingress Protection		IP34 (mounted)
---------------------------	--	----------------

ELECTRICAL SPECIFICATIONS

Nominal Current	mA	50 (stand-by), 300 (during tilt)
Ripple and Noise	mVpp and mV	20 (stand-by), 40 (during tilt)

**ACU-A20-S**

Optimizer RT® Antenna Control Unit AISG 2.0

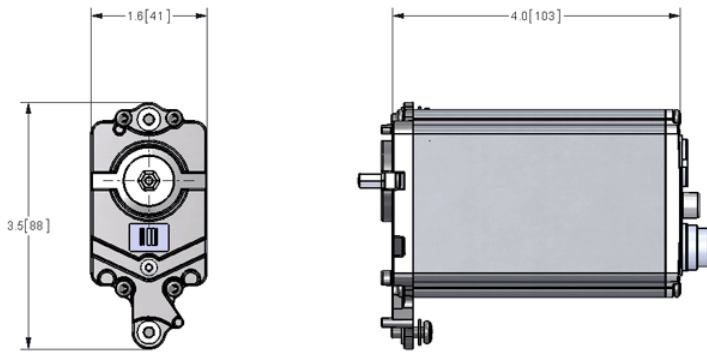
**External Document Links**[ACU-A20-S Installation Instructions](#)**Notes**

- Radiated emission in the semi anechoic chamber: EN 55022 (1998), with the limits class B specified in the EN 300386 V1.3.3 (2005)
- Radiated emission in the semi anechoic chamber: FCC part 15
- Conducted emission on the data cable: EN 55022 (1998), with the limits class B specified in the EN 300386 V1.3.3 (2005)
- Immunity to electrostatic discharges: EN 61000-4-2, {with the acceptance criteria B for the levels specified in the EN 300386 V1.3.3
- Immunity to radiated electromagnetic field: EN 61000-4-3, with the acceptance criteria A for the levels specified in the EN 300386 V1.3.3
- Immunity to radiated electromagnetic field : AISG1.1 and AISG 2.0, with the acceptance criteria A for the levels specified in the AISG1.1 and AISG 2.0
- Immunity to fast transient signals in bursts on the cable: EN 61000-4-4, with the acceptance criteria B for the levels specified in the EN300386 V1.3.3
- Immunity to surges (lighting protection): EN 61000-4-5, with the acceptance criteria B for the levels specified in the EN 300386 V1.3.3