

Stand-Off Bracket, 24 in, includes pipe

## Product Classification

**Product Type** Stand-off mount

## Dimensions

**Height** 609.6 mm | 24.0 in  
**Length** 609.6 mm | 24.0 in  
**Pipe Outer Diameter** 47.6 mm | 1 7/8 in  
**Weight** 9.9 kg | 21.9 lb  
**Width** 127.0 mm | 5.0 in

## Environmental Specifications

**Wind Rating** 120 mph (BWS) at 150 ft AGL

**Wind Rating Test Method** TIA/EIA-222

## General Specifications

**Stand-off Distance** 609.6 mm | 24.0 in  
**Includes** Clamps | Stand-off  
**Material Type** Hot dip galvanized steel  
**Mounting** Straight or tapered legs up to 88.9 mm (3-1/2 in) OD, clamps included  
**Note** One 20 ft omni antenna  
**Package Quantity** 1  
**Pipe Length** 609.6 mm | 24.0 in  
**Pipe, quantity** 1  
**Tower Taper** Non-tapered | Tapered

## Outline Drawing

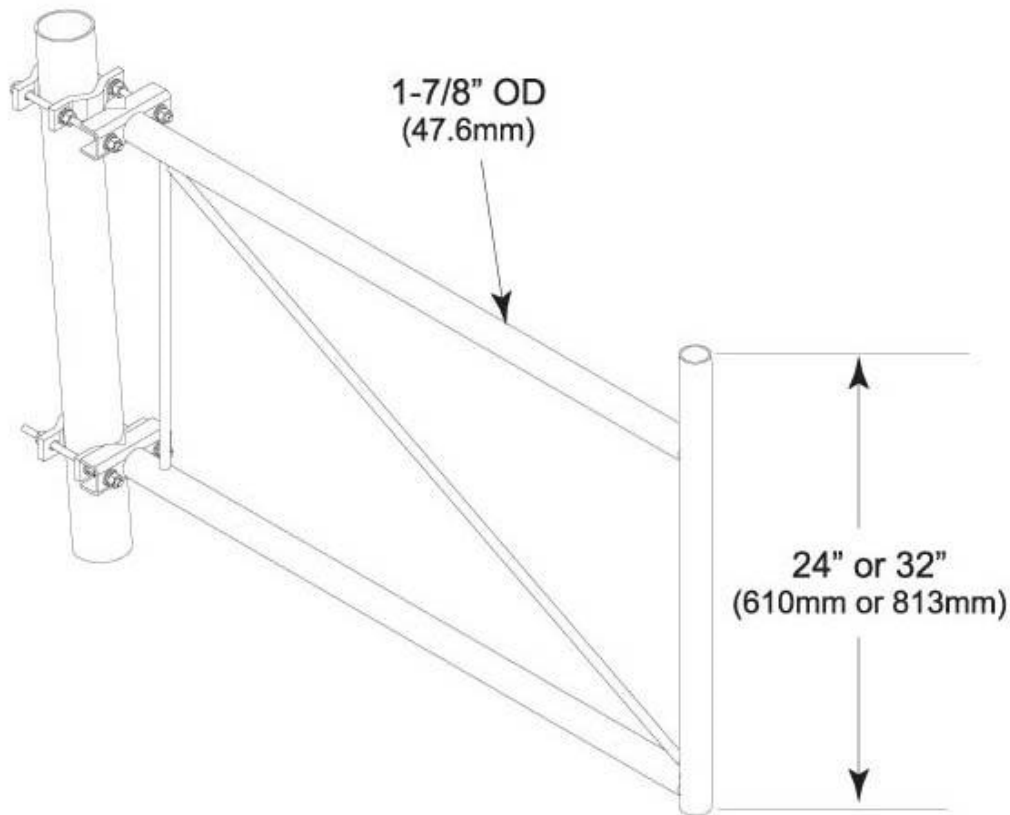

## Regulatory Compliance/Certifications

**Agency**

ISO 9001:2015

**Classification**

Designed, manufactured and/or distributed under this quality management system



## \* Footnotes

**Wind Rating**

BWS—Base Wind Speed; FBC—Florida Building Code