

NOTES:

- 1.0 GENERAL
- 1.1 ALL METRIC DIMENSIONS ARE IN BRACKETS
- 2.0 DESIGN NOTES
- 3.0 MANUFACTURING/SPECIAL REQUIRMENTS
- 4.0 TEST
- 5.0 PACKAGING

REVISIONS				
REV.	ECN	DESCRIPTION	BY	DATE
A	8000030684	INITIAL RELEASE	RDL5	07/13/18
B	8000032546	ADDED VIEWS TO HELP ASSEMBLY	MRC	11/19/18
C	8000032869	ADDED NEW PARTS, SCREWS, AND UPDATED NOTES	MRC	12/18/18
D	8000034701	CORRECTED MASS CALCULATION	ES1081	03/29/19

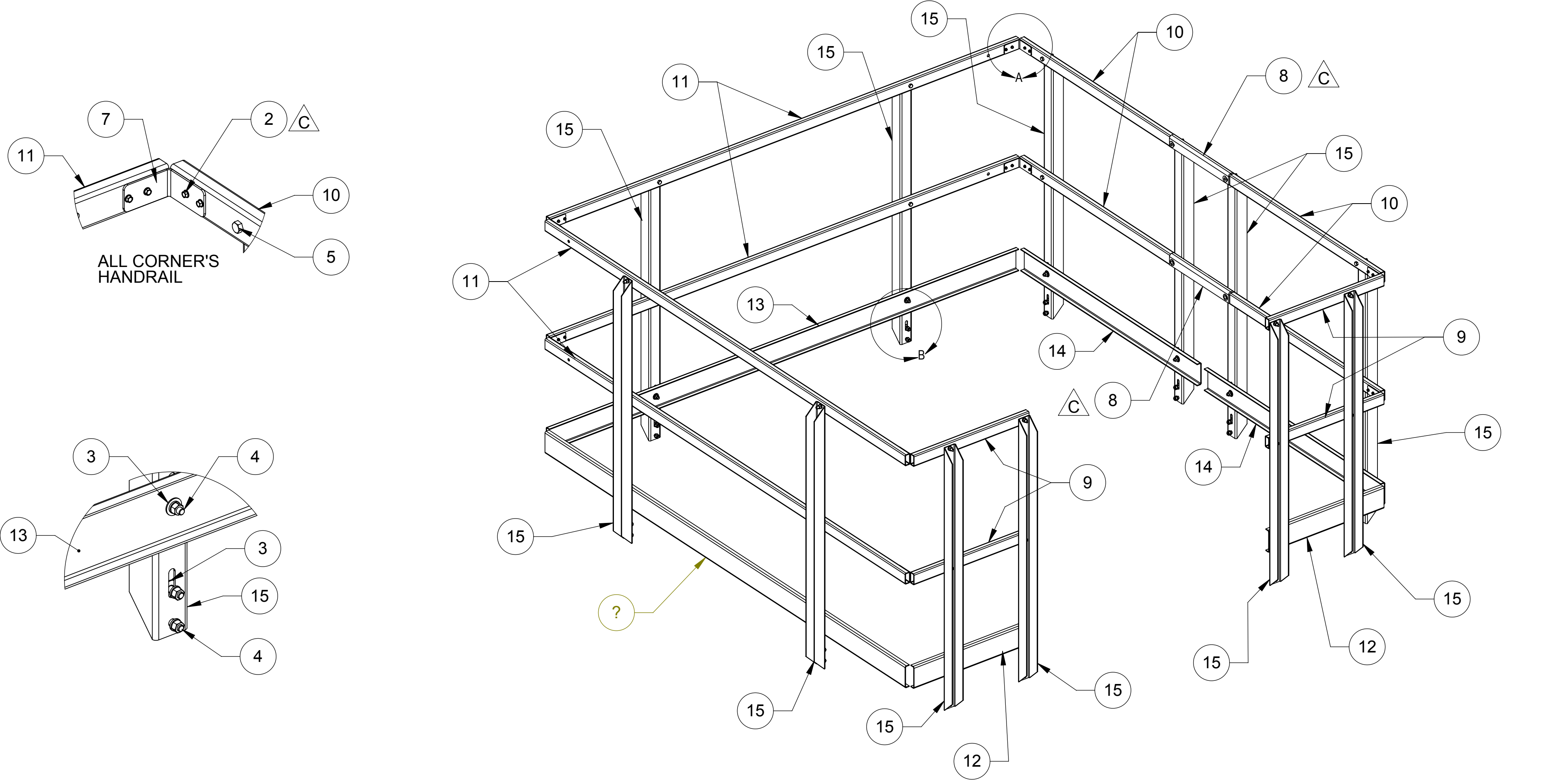

ALL CORNER'S HANDRAIL

ITEM	PART NO.	DESCRIPTION	QTY.	WEIGHT	NOTE NO.
1	TS1220	12-24 X 2" SELF DRILLING SCREW	12	0.03 LBS	
2	TS1288	12-24 X 7/8" SELF DRILLING SCREW	32	0.01LBS	
3	GW-03	3/8" GALV FLAT WASHER	28	0.01 LBS	
4	GB-03105	3/8" X 1" GALV BOLT KIT	36	0.05 LBS	
5	GB-03205	3/8" X 2" GALV BOLT KIT	24	0.08 LBS	
6	MTC9410WFW	5/16" GALV, WIDE FLAT WASHER 7/8" OD	6	0.01 LBS	
7	MTC3979HR19	ANGLE BRKT, HANDRAIL	8	0.32 LBS	
8	MTC4037HR21	FORMED ANGLE, HANDRAIL STIFFENER	2	2.08 LBS	
9	MTC4037HR12	HANDRAIL, HORIZONTAL, 23"	4	4.10 LBS	
10	MTC4037HR14	HANDRAIL, HORIZONTAL, 46"	4	8.22 LBS	
11	MTC40378816	HANDRAIL, HORIZONTAL, 94"	4	16.80 LBS	
12	MTC4037HR13	PLATE, HANDRAIL TOEBOARD	2	4.04 LBS	
13	MTC4037HR15	PLATE, HANDRAIL TOEBOARD	2	16.58 LBS	
14	MTC4037HR16	PLATE, HANDRAIL TOEBOARD	2	8.11 LBS	
15	MTC403721	POST, HANDRAIL	12	9.98 LBS	

COMMSCOPE, INC. OF NORTH CAROLINA

TOLERANCES		SAP MATERIAL MASTER																																		
0 PLACE X ± 0.25	2 PLACE .XX ± 0.06	MTC4037HR																																		
1 PLACE .X ± 0.12	ANGLES ± 2°																																			
FINISH GALV A123		MATERIAL A1011/A1018, A500																																		
<table border="1" style="font-size: small;"> <thead> <tr> <th>NAME</th> <th>DATE</th> <th>TITLE</th> </tr> </thead> <tbody> <tr> <td>CE MRC</td> <td>06/26/18</td> <td rowspan="5" style="text-align: center; vertical-align: middle;">8x8 PLATFORM HANDRAIL W TOE BOARD</td> </tr> <tr> <td>RW EST081</td> <td>03/29/2019</td> </tr> <tr> <td>RV</td> <td></td> </tr> <tr> <td>AD RD1048</td> <td>04/12/2019</td> </tr> <tr> <td>RE RD1048</td> <td>04/12/2019</td> </tr> </tbody> </table>		NAME	DATE	TITLE	CE MRC	06/26/18	8x8 PLATFORM HANDRAIL W TOE BOARD	RW EST081	03/29/2019	RV		AD RD1048	04/12/2019	RE RD1048	04/12/2019	<table border="1" style="font-size: small;"> <tr> <td>SCALE</td> <td>DOCUMENT NO.</td> </tr> <tr> <td style="text-align: center;">1:12</td> <td style="text-align: center;">MTC4037HR</td> </tr> </table>		SCALE	DOCUMENT NO.	1:12	MTC4037HR															
NAME	DATE	TITLE																																		
CE MRC	06/26/18	8x8 PLATFORM HANDRAIL W TOE BOARD																																		
RW EST081	03/29/2019																																			
RV																																				
AD RD1048	04/12/2019																																			
RE RD1048	04/12/2019																																			
SCALE	DOCUMENT NO.																																			
1:12	MTC4037HR																																			
<table border="1" style="font-size: x-small;"> <tr> <td>DENSITY</td> <td>0</td> <td>lbs/in³</td> </tr> <tr> <td>MASS</td> <td>300</td> <td>lbs</td> </tr> <tr> <td>VOLUME</td> <td></td> <td>in³</td> </tr> <tr> <td>SURFACE AREA</td> <td></td> <td>in²</td> </tr> </table>		DENSITY	0	lbs/in ³	MASS	300	lbs	VOLUME		in ³	SURFACE AREA		in ²	<table border="1" style="font-size: x-small;"> <tr> <td>SIZE</td> <td>WORK AREA</td> <td>24</td> <td>MODEL</td> <td colspan="3"></td> </tr> <tr> <td rowspan="2" style="text-align: center;">C</td> <td rowspan="2" style="text-align: center;"> </td> <td>VERSION</td> <td>STATUS</td> <td>REVISION</td> <td>VERSION</td> <td>STATUS</td> <td>REVISION</td> </tr> <tr> <td>04</td> <td>RE</td> <td>C</td> <td>04</td> <td>RE</td> <td>D</td> </tr> </table>		SIZE	WORK AREA	24	MODEL				C		VERSION	STATUS	REVISION	VERSION	STATUS	REVISION	04	RE	C	04	RE	D
DENSITY	0	lbs/in ³																																		
MASS	300	lbs																																		
VOLUME		in ³																																		
SURFACE AREA		in ²																																		
SIZE	WORK AREA	24	MODEL																																	
C		VERSION	STATUS	REVISION	VERSION	STATUS	REVISION																													
		04	RE	C	04	RE	D																													

4

3

2

1

NOTES:

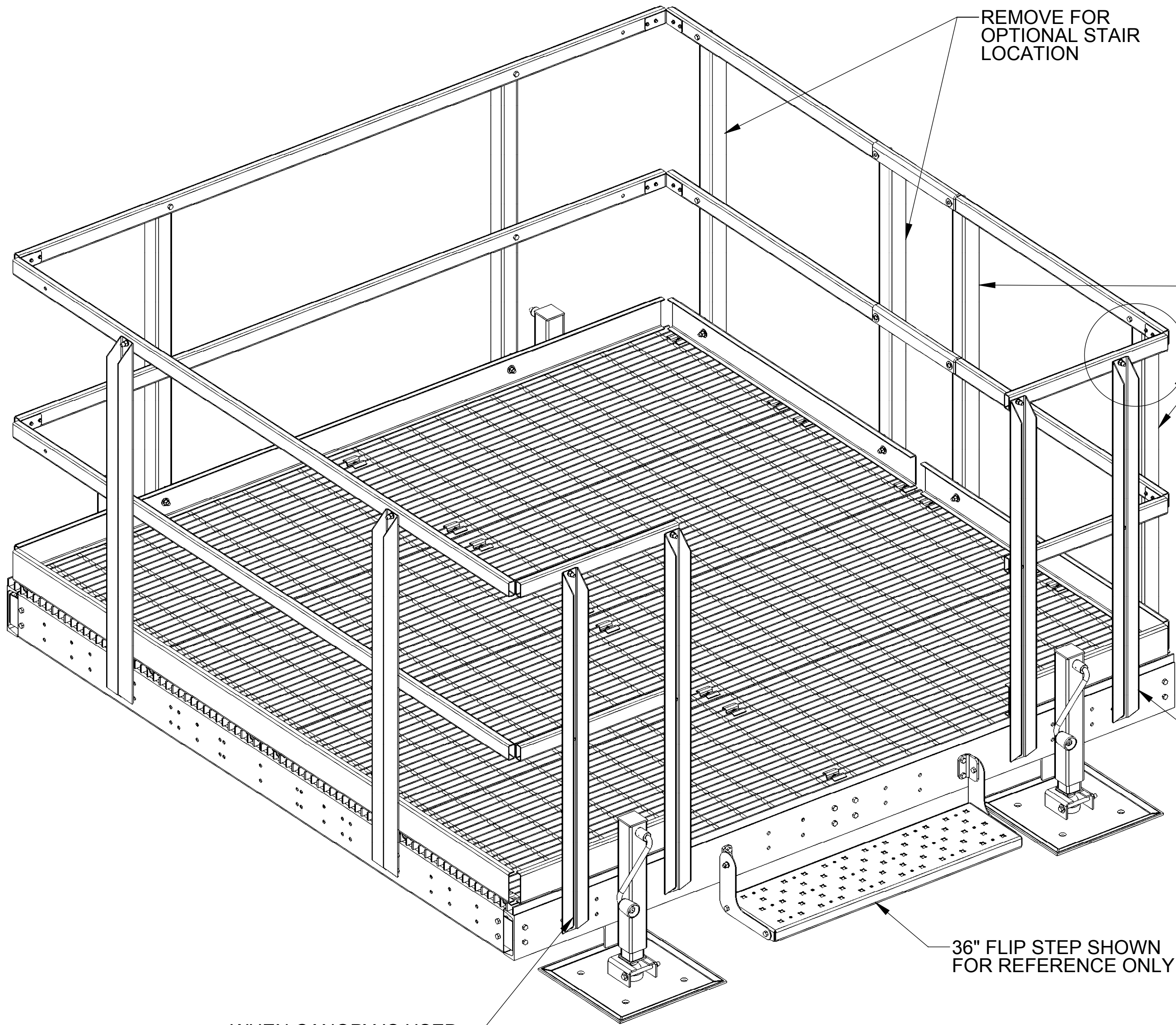

REMOVE FOR
OPTIONAL STAIR
LOCATION

REMOVE FOR
OPTIONAL STAIR
LOCATION

WHEN CANOPY IS USED
REMOVE POST AND TECH
SCREW HANDRAIL INTO 4"
CANOPY POST WITH TWO
TS1220 SCREWS PER POST

36" FLIP STEP SHOWN
FOR REFERENCE ONLY

WHEN CANOPY IS USED
REMOVE POST AND TECH
SCREW HANDRAIL INTO 4"
CANOPY POST WITH TWO
TS1220 SCREWS PER POST

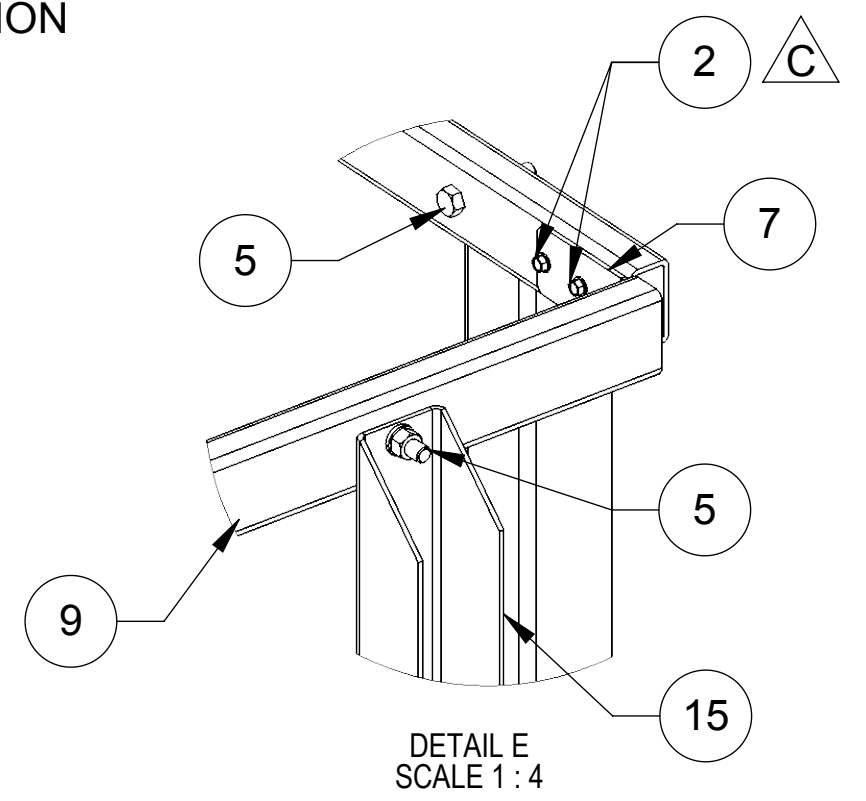

DETAIL E
SCALE 1:4

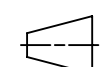
COMMSCOPE, INC. OF NORTH CAROLINA				
TITLE 8x8 PLATFORM HANDRAIL W TOE BOARD				
SIZE C	SCALE 1:10	DOCUMENT NO. MTC4037HR		
 		DRAWING		SHEET 2 OF 6
		VERSION 04	STATUS RE	

© 2018 CommScope, Inc.

4

3

2

1

D

D

C

C

B

B

A

A

4

3

2

1

NOTES:

CANOPY SHOWN FOR REFERENCE ONLY.
SOLD SEPARATELY

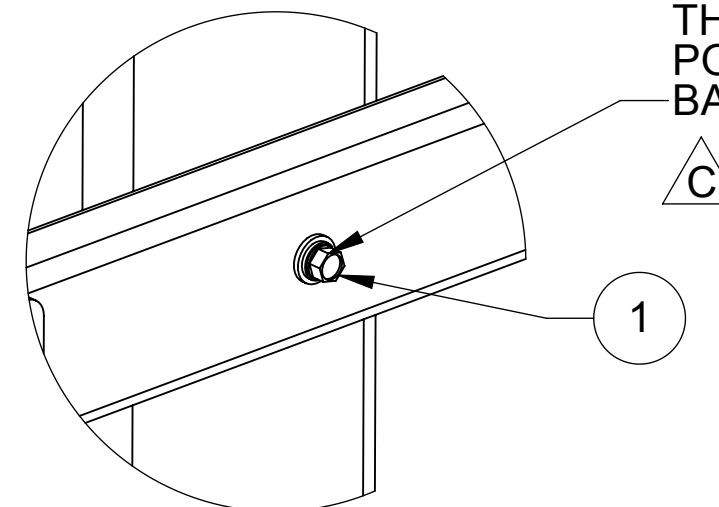
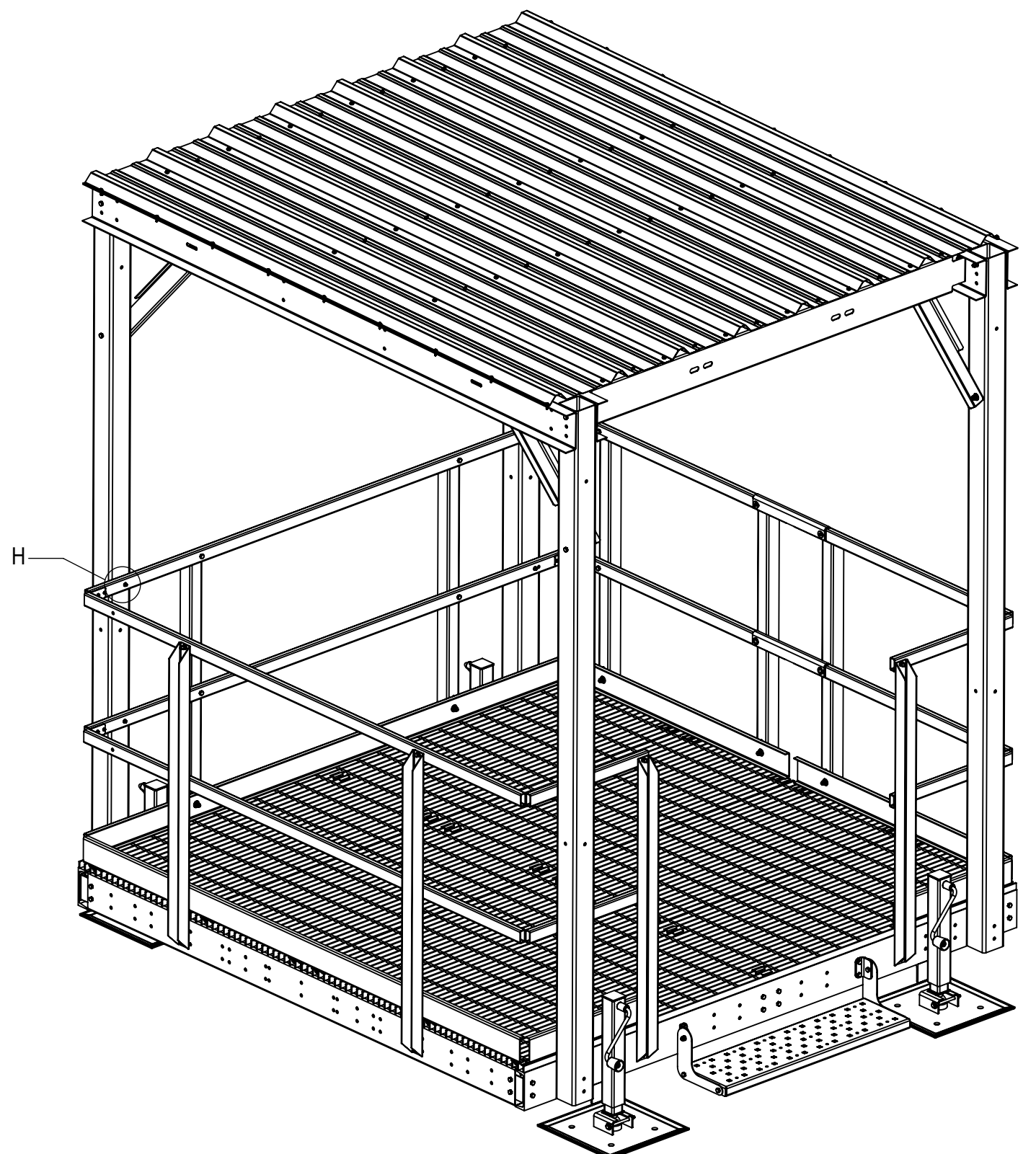
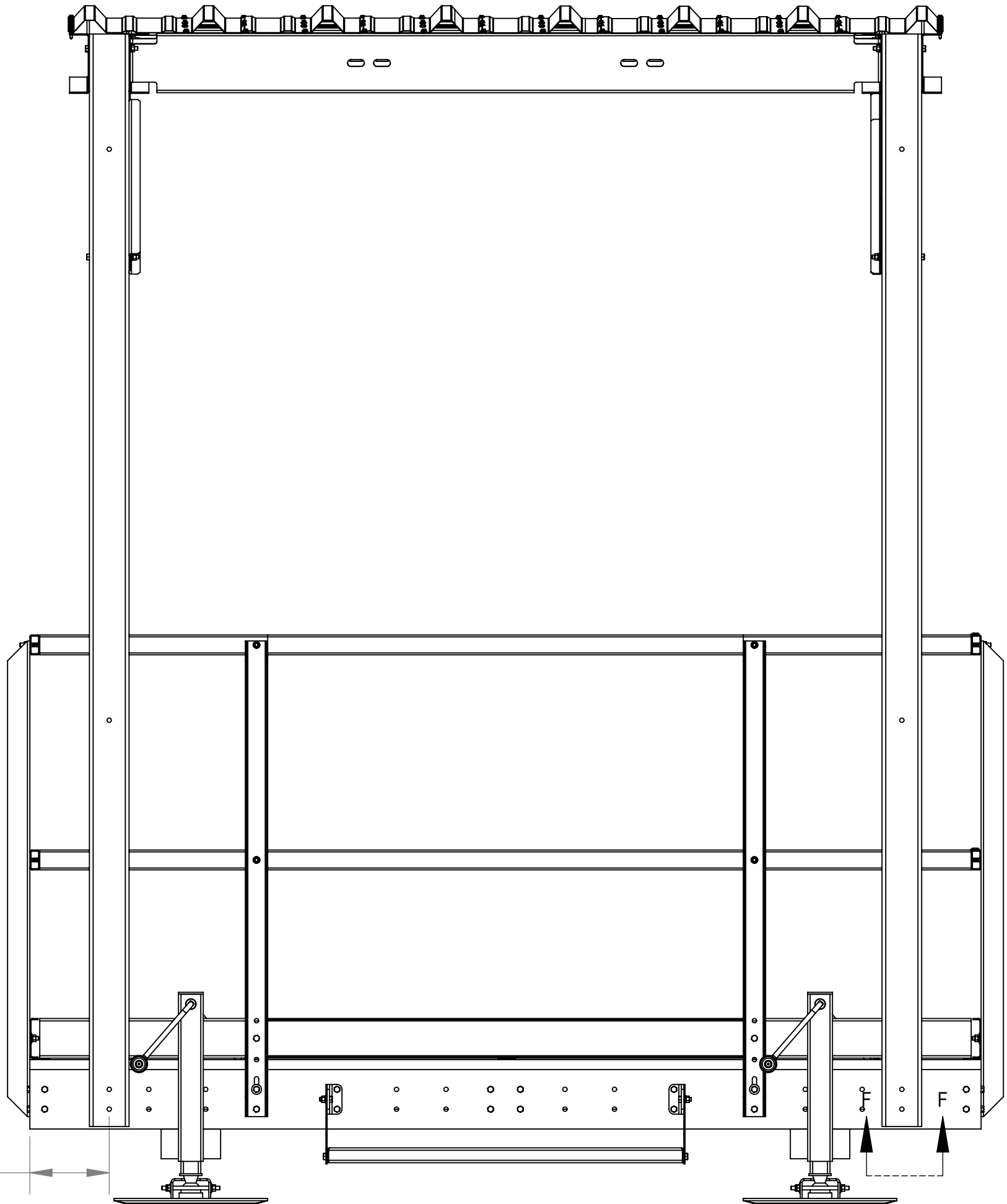

DETAIL H
SCALE 1 : 2

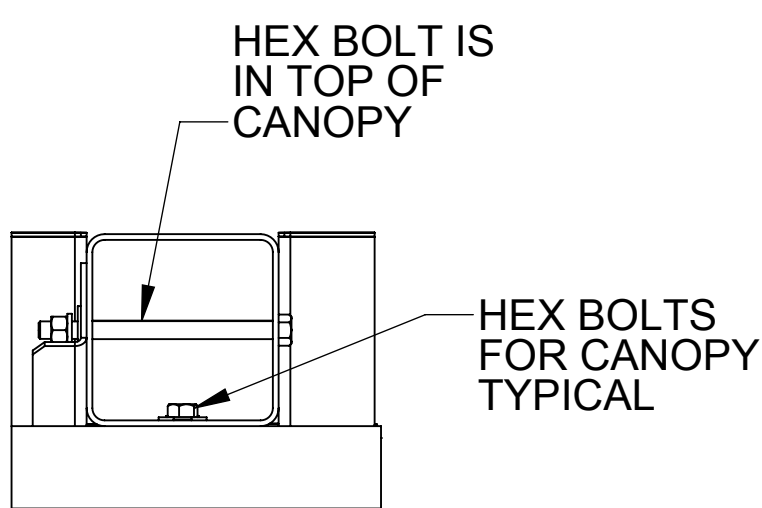

SECTION F-F
SCALE 1 : 4

COMMSCOPE, INC. OF NORTH CAROLINA				
TITLE 8x8 PLATFORM HANDRAIL W TOE BOARD				
SIZE C	SCALE 1:12	DOCUMENT NO. MTC4037HR		
		DRAWING		SHEET
		VERSION	STATUS	REVISION
		04	RE	D
				3 OF 6

© 2018 CommScope, Inc.

4

3

2

1

4

3

2

1

NOTES:

CANOPY SHOWN FOR REFERENCE ONLY.
SOLD SEPARATELY

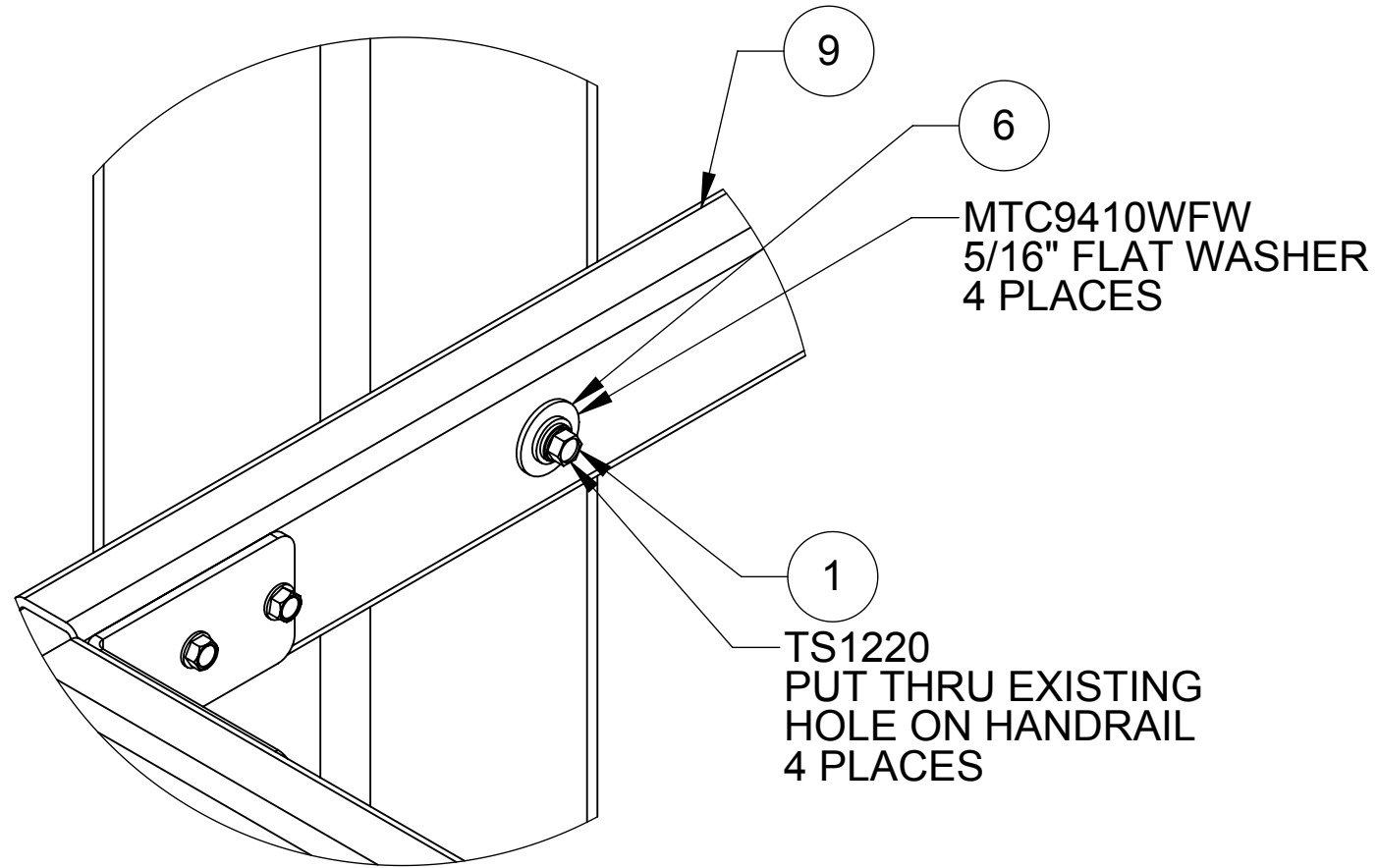

DETAIL J
SCALE 1:2

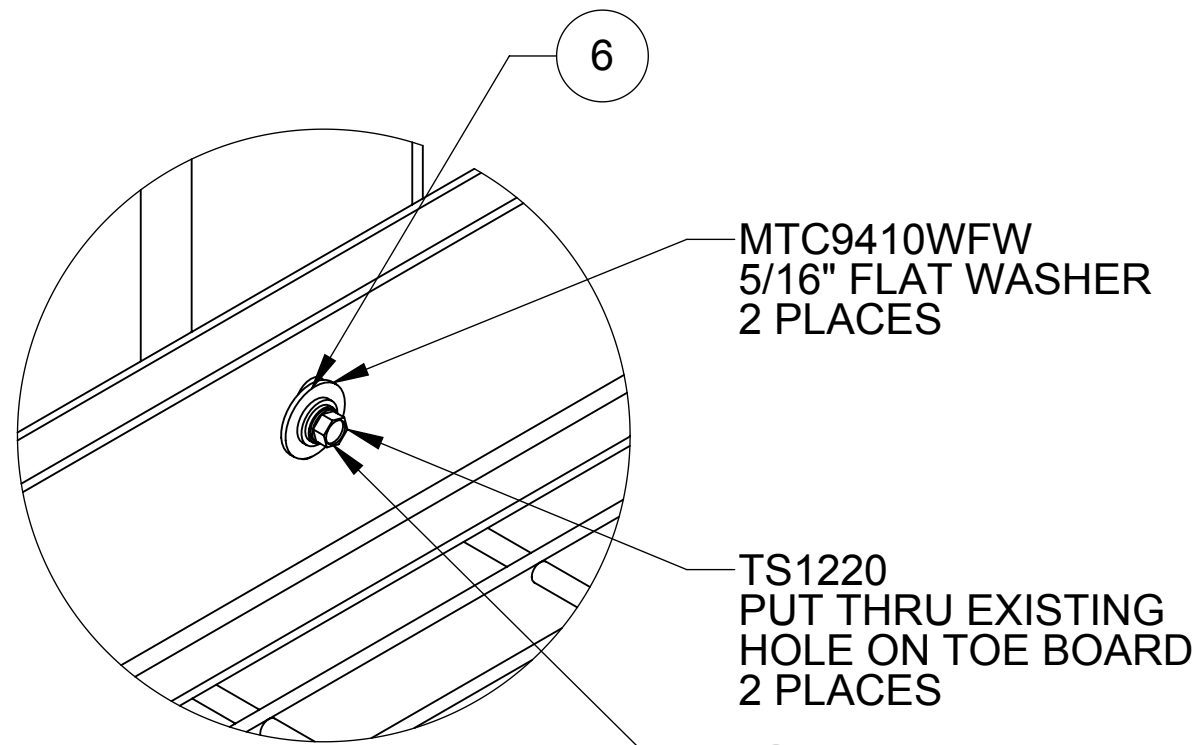
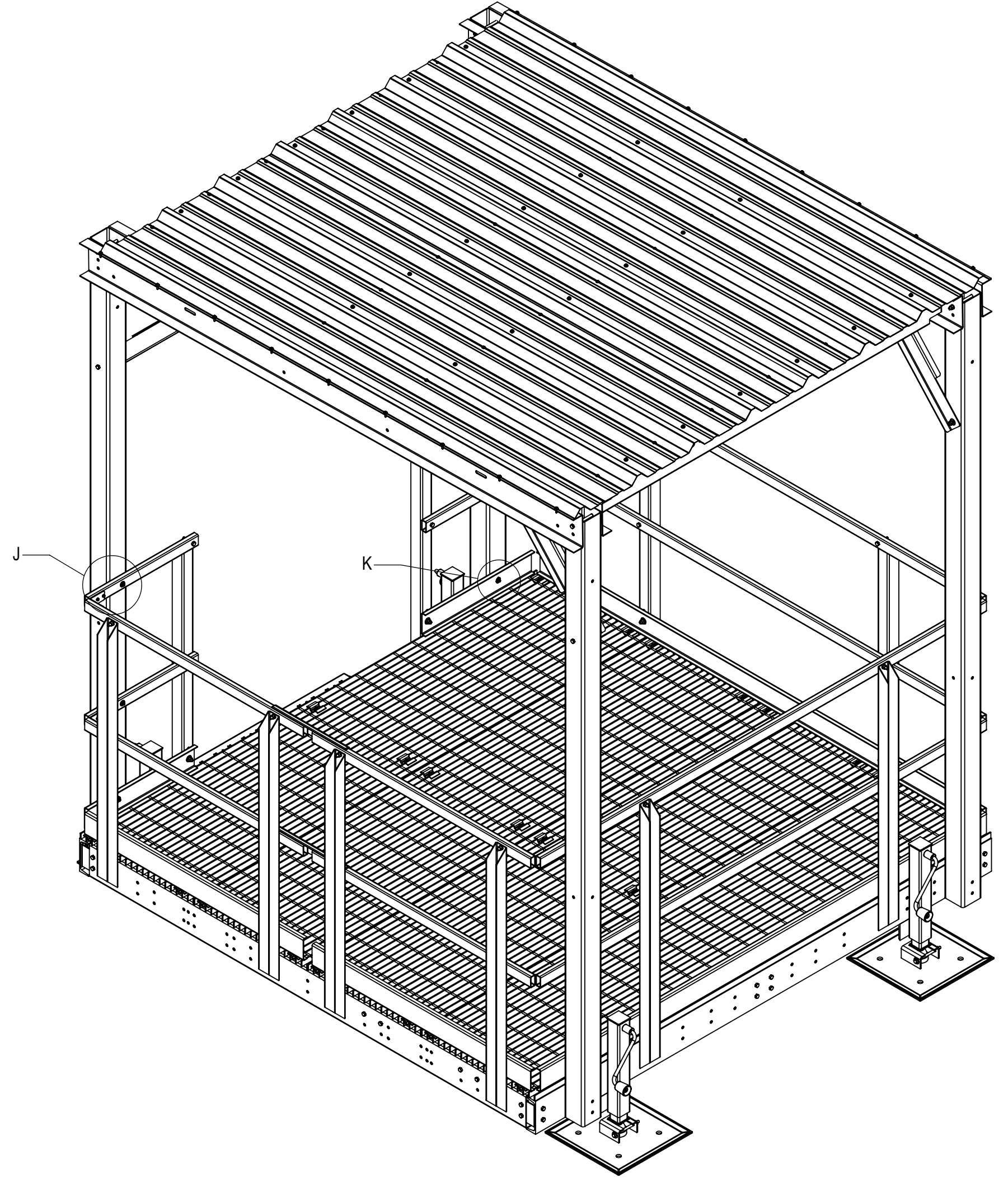

DETAIL K
SCALE 1:2

COMMSCOPE, INC. OF NORTH CAROLINA				
TITLE 8x8 PLATFORM HANDRAIL W TOE BOARD				
SIZE C	SCALE 1:16	DOCUMENT NO. MTC4037HR		
		DRAWING		SHEET
		VERSION 04	STATUS RE	REVISION D
				4 OF 6

© 2018 CommScope, Inc.

4

3

2

1



D

D

C

C

B

B

A

A

4

3

2

1

NOTES:

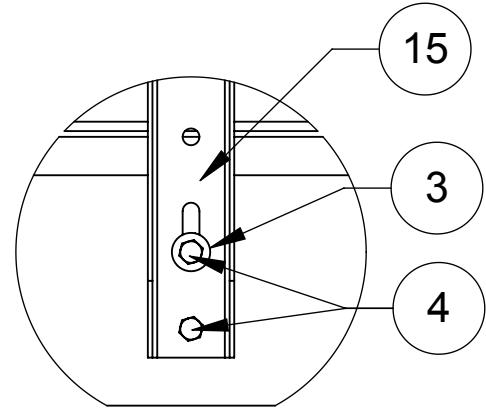
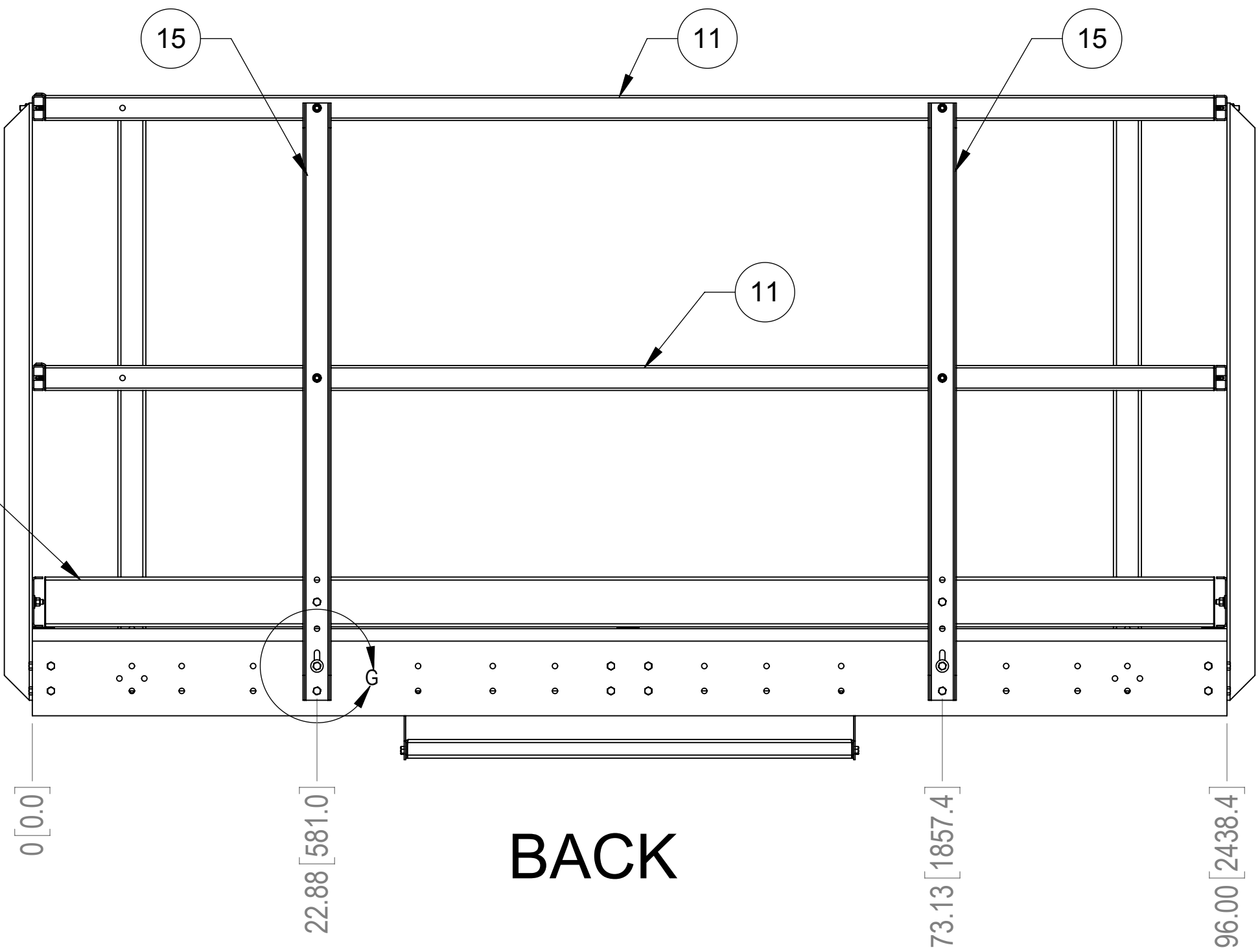
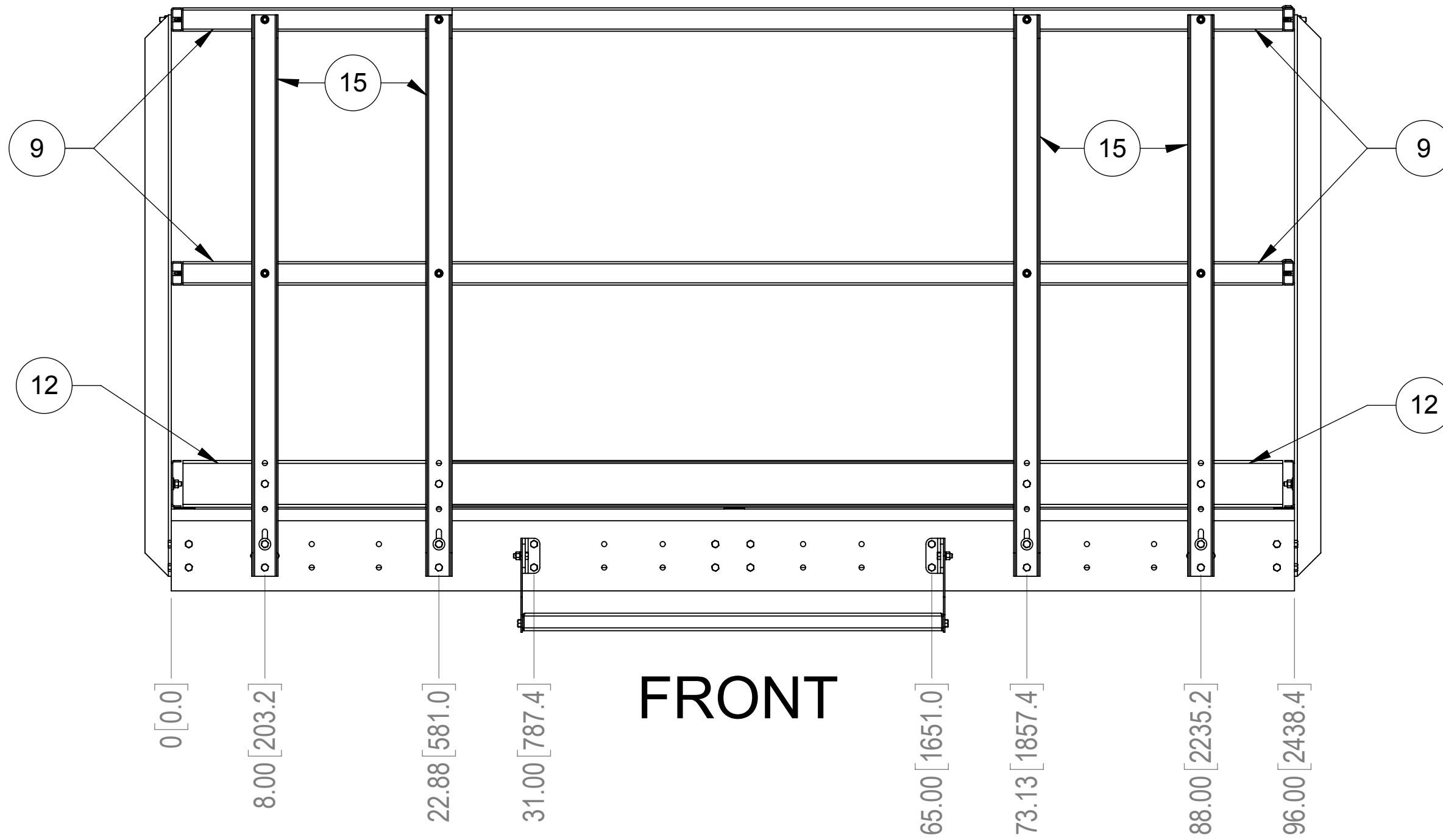

TYPICAL ALL HANDRAIL POSTS

DETAIL G
SCALE 1:5

COMMSCOPE, INC. OF NORTH CAROLINA				
TITLE 8x8 PLATFORM HANDRAIL W TOE BOARD				
SIZE C	SCALE 1:10	DOCUMENT NO. MTC4037HR		
		DRAWING		SHEET
		VERSION	STATUS	REVISION
		04	RE	D
				SHEET 5 OF 6

© 2018 CommScope, Inc.

4

3

2

1

D

D

C

C

B

B



A

A

NOTES:

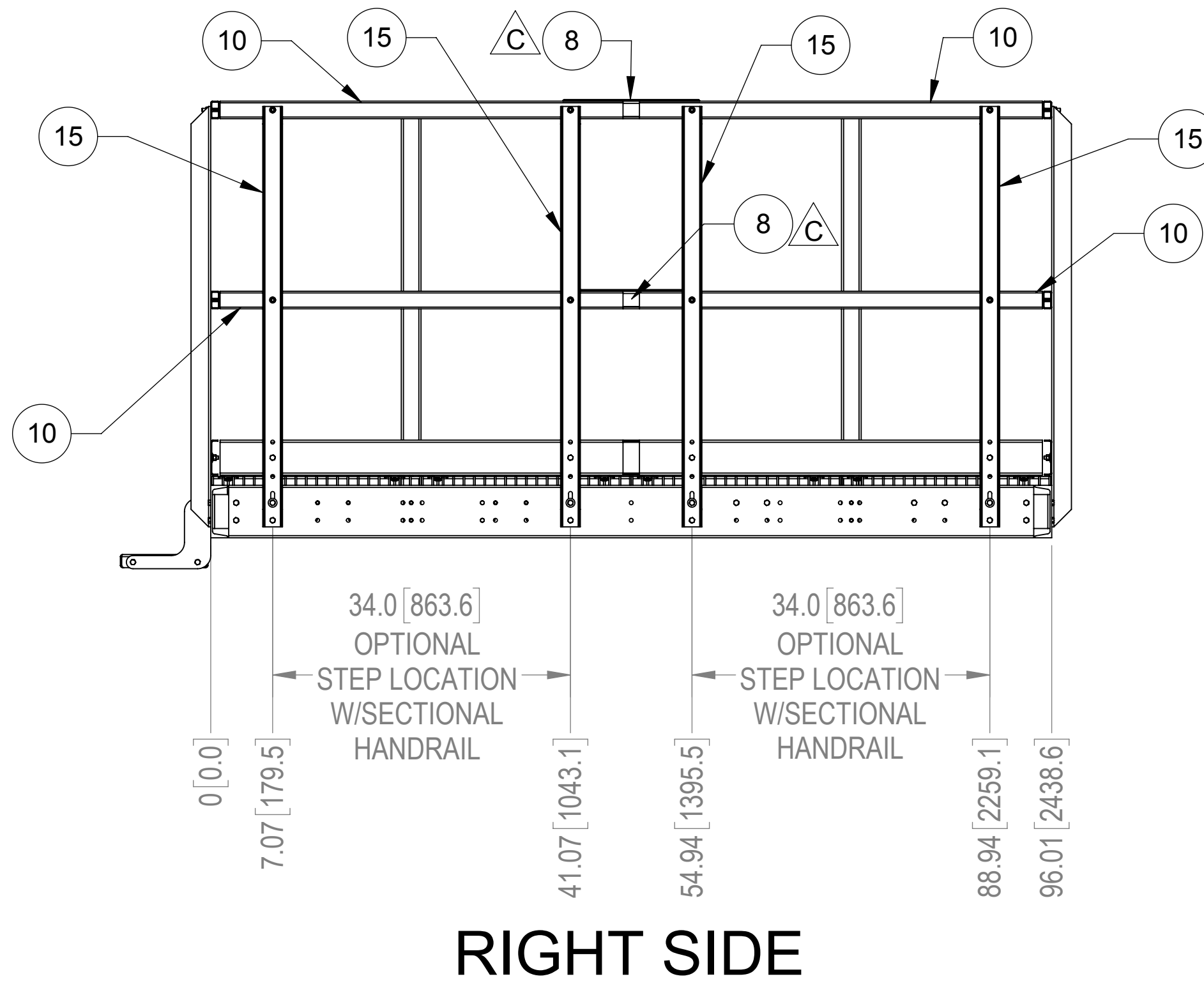
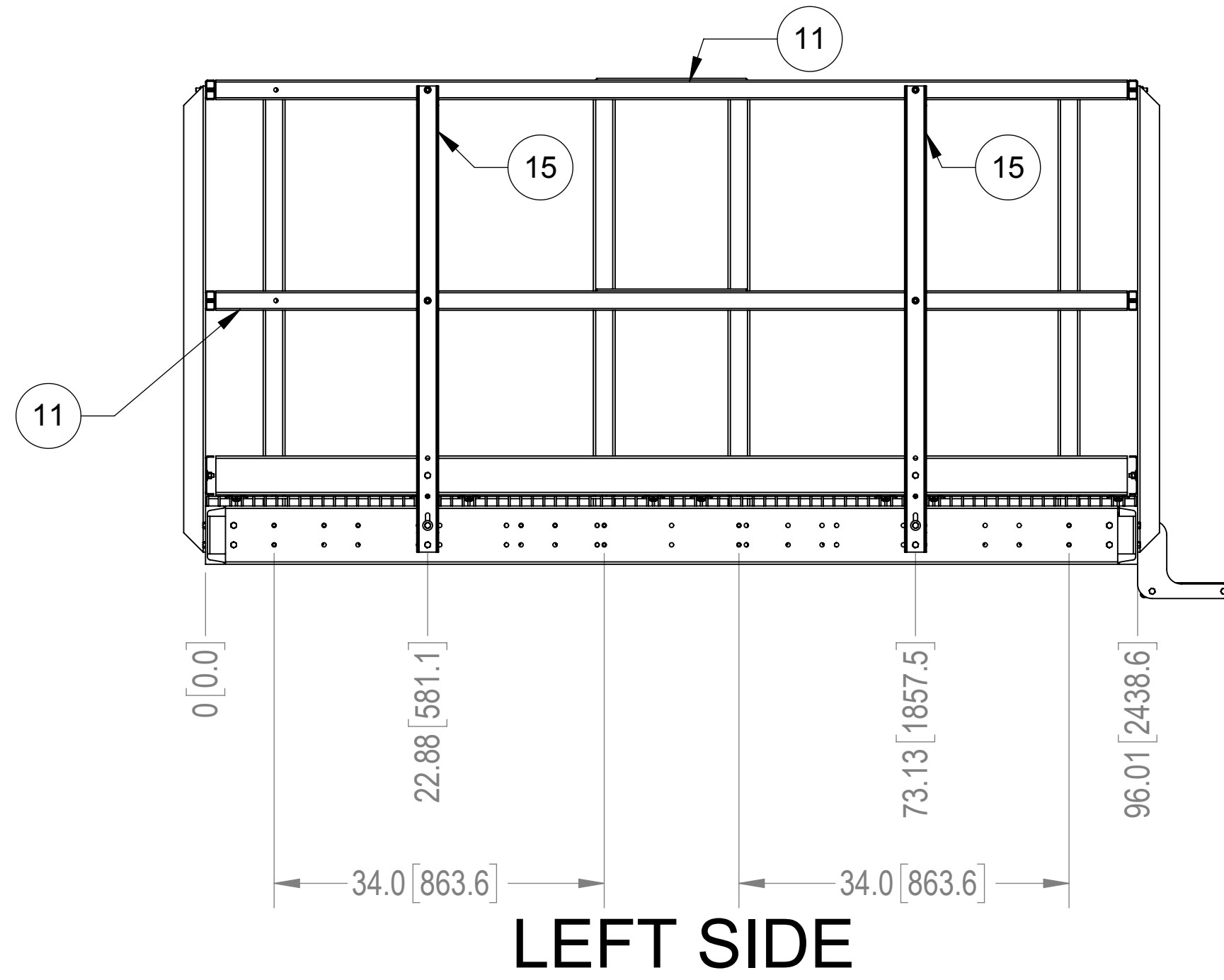
1.0 HAND RAIL & STEP
CAN BE MOUNTED
TO EITHER SIDE



COMMSCOPE, INC. OF NORTH CAROLINA				
TITLE 8x8 PLATFORM HANDRAIL W TOE BOARD				
SIZE C	SCALE 1:14	DOCUMENT NO. MTC4037HR		
 		DRAWING		SHEET
		VERSION 04	STATUS RE	REVISION D