

SECTION A-A

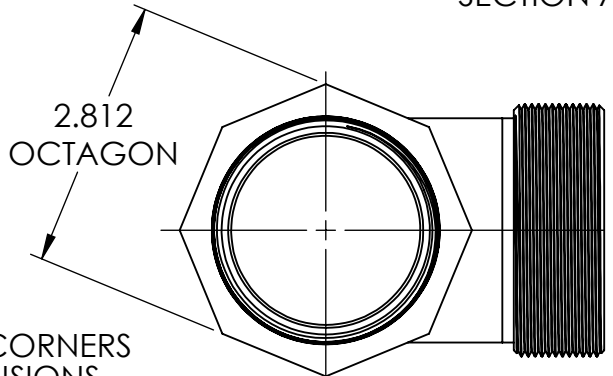

- NOTES:
 1.) PART TO BE FREE OF BURRS AND SHARP CORNERS
 2.) * INDICATES CRITICAL INSPECTION DIMENSIONS

REV.	DATE	CHANGE	UNLESS OTHERWISE SPECIFIED:	NAME	DATE	REMKE REMKE INDUSTRIES 310 CHADDICK DR, WHEELING, IL. 60090	
A	3/17/10	REDRAWN IN CAD LT, ALSO CHANGED 11 DEG. ANGLE TO 6° & NEW DIM 2.220 WAS 2.24 CAST, ALSO ADDED .032 X 45° I.D. CHAMFER, ALSO REVISED LENGTH AND DIAMETERS OF 2" NPT PROFILE APPROVED C.V.	DIMENSIONS ARE IN INCHES TOLERANCES: FRACTIONAL ± 1/64 ANGULAR: MACH ± 1° BEND ± 1° ONE PLACE DECIMAL ± .015 TWO PLACE DECIMAL ± .010 THREE PLACE DECIMAL ± .005	DRAWN JCN	8/14	TITLE: BODY	
B	3/18/13	CORRECTED PITCH DIAMETERS FOR 2-5/8-14 THREAD	INTERPRET GEOMETRIC TOLERANCING PER:	CHECKED		SIZE DWG. NO. A RSR-9600-B	
C	8/20/14	REDRAWN	MATERIAL ALUMINUM	ENG APPR.		SCALE: 1:2	
			FINISH	MFG APPR.		SHEET 1 OF 1	
			DO NOT SCALE DRAWING	Q.A.			
				PROPRIETARY AND CONFIDENTIAL THE INFORMATION CONTAINED IN THIS DRAWING IS THE SOLE PROPERTY OF REMKE INDUSTRIES. ANY REPRODUCTION IN PART OR AS A WHOLE WITHOUT THE WRITTEN PERMISSION OF REMKE INDUSTRIES IS PROHIBITED.			