

Product Selection

Catalog Number Description

| | | | | | | | |
|------------|---|----------------|------------|-----------|----------|----------------|----------|
| 25B | - | V | 2P5 | N | 1 | 0 | 4 |
| Drive | | Voltage Rating | Rating | Enclosure | HIM | Emission Class | Version |

PowerFlex 520-Series Drive Ratings

| PowerFlex 523 Catalog No. | PowerFlex 525 Catalog No. | Output Ratings | | | | Output Current (A) | Input Voltage Range | Total Watts Loss | Frame Size |
|--|------------------------------|----------------|------|------------|------|--------------------|---------------------|------------------|------------|
| | | Normal Duty | | Heavy Duty | | | | | |
| | | HP | kW | HP | kW | | | | |
| 100...120V AC (-15%, +10%) - 1-Phase Input, 0...230V 3-Phase Output | | | | | | | | | |
| 25A-V1P6N104 | - | 0.25 | 0.2 | 0.25 | 0.2 | 1.6 | 85...132 | 20.0 | A |
| 25A-V2P5N104 | 25B-V2P5N104 | 0.5 | 0.4 | 0.5 | 0.4 | 2.5 | 85...132 | 27.0 | A |
| 25A-V4P8N104 | 25B-V4P8N104 | 1.0 | 0.75 | 1.0 | 0.75 | 4.8 | 85...132 | 53.0 | B |
| 25A-V6PON104 | 25B-V6PON104 | 1.5 | 1.1 | 1.5 | 1.1 | 6.0 | 85...132 | 67.0 | B |
| 200...240V AC (-15%, +10%) - 1-Phase Input, 0...230V 3-Phase Output | | | | | | | | | |
| 25A-A1P6N104 | - | 0.25 | 0.2 | 0.25 | 0.2 | 1.6 | 85...132 | 20.0 | A |
| 25A-A2P5N104 | 25B-A2P5N104 | 0.5 | 0.4 | 0.5 | 0.4 | 2.5 | 170...264 | 29.0 | A |
| 25A-A4P8N104 | 25B-A4P8N104 | 1.0 | 0.75 | 1.0 | 0.75 | 4.8 | 170...264 | 50.0 | A |
| 25A-A8PON104 | 25B-A8PON104 | 2.0 | 1.5 | 2.0 | 1.5 | 8.0 | 170...264 | 81.0 | B |
| 25A-A011N104 | 25B-A011N104 | 3.0 | 2.2 | 3.0 | 2.2 | 11.0 | 170...264 | 111.0 | B |
| 200...240V AC (-15%, +10%) - 1-Phase Input with EMC Filter, 0...230V 3-Phase Output | | | | | | | | | |
| 25A-A1P6N114 | - | 0.25 | 0.2 | 0.25 | 0.2 | 1.6 | 85...132 | 20.0 | A |
| 25A-A2P5N114 | 25B-A2P5N114 | 0.5 | 0.4 | 0.5 | 0.4 | 2.5 | 170...264 | 29.0 | A |
| 25A-A4P8N114 | 25B-A4P8N114 | 1.0 | 0.75 | 1.0 | 0.75 | 4.8 | 170...264 | 53.0 | A |
| 25A-A8PON114 | 25B-A8PON114 | 2.0 | 1.5 | 2.0 | 1.5 | 8.0 | 170...264 | 84.0 | B |
| 25A-A011N114 | 25B-A011N114 | 3.0 | 2.2 | 3.0 | 2.2 | 11.0 | 170...264 | 116.0 | B |
| 200...240V AC (-15%, +10%) - 3-Phase Input, 0...230V 3-Phase Output | | | | | | | | | |
| 25A-B1P6N104 | - | 0.25 | 0.2 | 0.25 | 0.2 | 1.6 | 85...132 | 20.0 | A |
| 25A-B2P5N104 | 25B-B2P5N104 | 0.5 | 0.4 | 0.5 | 0.4 | 2.5 | 170...264 | 29.0 | A |
| 25A-B5PON104 | 25B-B5PON104 | 1.0 | 0.75 | 1.0 | 0.75 | 5.0 | 170...264 | 50.0 | A |
| 25A-B8PON104 | 25B-B8PON104 | 2.0 | 1.5 | 2.0 | 1.5 | 8.0 | 170...264 | 79.0 | A |
| 25A-B011N104 | 25B-B011N104 | 3.0 | 2.2 | 3.0 | 2.2 | 11.0 | 170...264 | 107.0 | A |
| 25A-B017N104 | 25B-B017N104 | 5.0 | 4.0 | 5.0 | 4.0 | 17.5 | 170...264 | 148.0 | B |
| 25A-B024N104 | 25B-B024N104 | 7.5 | 5.5 | 7.5 | 5.5 | 24.0 | 170...264 | 259.0 | C |
| 25A-B032N104 | 25B-B032N104 | 10.0 | 7.5 | 10.0 | 7.5 | 32.2 | 170...264 | 323.0 | D |
| 25A-B048N104 | 25B-B048N104 | 15.0 | 11.0 | 10.0 | 7.5 | 48.3 | 170...264 | 584.0 | E |
| 25A-B062N104 | 25B-B062N104 | 20.0 | 15.0 | 15.0 | 11.0 | 62.1 | 170...264 | 708.0 | E |
| 380...480V AC (-15%, +10%) - 3-Phase Input, 0...460V 3-Phase Output⁽¹⁾ | | | | | | | | | |
| 25A-D1P4N104 | 25B-D1P4N104 | 0.5 | 0.4 | 0.5 | 0.4 | 1.4 | 323...528 | 27.0 | A |
| 25A-D2P3N104 | 25B-D2P3N104 | 1.0 | 0.75 | 1.0 | 0.75 | 2.3 | 323...528 | 37.0 | A |
| 25A-D4PON104 | 25B-D4PON104 | 2.0 | 1.5 | 2.0 | 1.5 | 4.0 | 323...528 | 62.0 | A |
| 25A-D6PON104 | 25B-D6PON104 | 3.0 | 2.2 | 3.0 | 2.2 | 6.0 | 323...528 | 86.0 | A |
| 25A-D010N104 | 25B-D010N104 | 5.0 | 4.0 | 5.0 | 4.0 | 10.5 | 323...528 | 129.0 | B |
| 25A-D013N104 | 25B-D013N104 | 7.5 | 5.5 | 7.5 | 5.5 | 13.0 | 323...528 | 170.0 | C |
| 25A-D017N104 | 25B-D017N104 | 10.0 | 7.5 | 10.0 | 7.5 | 17.0 | 323...528 | 221.0 | C |
| 25A-D024N104 | 25B-D024N104 | 15.0 | 11.0 | 15.0 | 11.0 | 24.0 | 323...528 | 303.0 | D |
| 25A-D030N104 | 25B-D030N104 | 20.0 | 15.0 | 15.0 | 11.0 | 30.0 | 323...528 | 387.0 | D |
| 380...480V AC (-15%, +10%) - 3-Phase Input with EMC Filter, 0...460V 3-Phase Output | | | | | | | | | |
| 25A-D1P4N114 | 25B-D1P4N114 | 0.5 | 0.4 | 0.5 | 0.4 | 1.4 | 323...528 | 27.0 | A |
| 25A-D2P3N114 | 25B-D2P3N114 | 1.0 | 0.75 | 1.0 | 0.75 | 2.3 | 323...528 | 37.0 | A |
| 25A-D4PON114 | 25B-D4PON114 | 2.0 | 1.5 | 2.0 | 1.5 | 4.0 | 323...528 | 63.0 | A |

PowerFlex 520-Series Drive Ratings (Continued)

| PowerFlex 523 Catalog No. | PowerFlex 525 Catalog No. | Output Ratings | | | | Input Voltage Range | Total Watts Loss | Frame Size | |
|--|------------------------------|----------------|------|------------|------|------------------------|------------------|------------|-----------------------|
| | | Normal Duty | | Heavy Duty | | | | | Output Current (A) |
| | | HP | kW | HP | kW | | | | |
| 25A-D6P0N1T4 | 25B-D6P0N1T4 | 3.0 | 2.2 | 3.0 | 2.2 | 6.0 | 323...528 | 88.0 | A |
| 25A-D010N1T4 | 25B-D010N1T4 | 5.0 | 4.0 | 5.0 | 4.0 | 10.5 | 323...528 | 133.0 | B |
| 25A-D013N1T4 | 25B-D013N1T4 | 7.5 | 5.5 | 7.5 | 5.5 | 13.0 | 323...528 | 175.0 | C |
| 25A-D017N1T4 | 25B-D017N1T4 | 10.0 | 7.5 | 10.0 | 7.5 | 17.0 | 323...528 | 230.0 | C |
| 25A-D024N1T4 | 25B-D024N1T4 | 15.0 | 11.0 | 15.0 | 11.0 | 24.0 | 323...528 | 313.0 | D |
| 25A-D030N1T4 | 25B-D030N1T4 | 20.0 | 15.0 | 15.0 | 11.0 | 30.0 | 323...528 | 402.0 | D |
| 25A-D037N1T4 | 25B-D037N1T4 | 25.0 | 18.5 | 20.0 | 15.0 | 37.0 | 323...528 | 602.0 | E |
| 25A-D043N1T4 | 25B-D043N1T4 | 30.0 | 22.0 | 25.0 | 18.5 | 43.0 | 323...528 | 697.0 | E |
| 525...600V AC (-15%, +10%) - 3-Phase Input, 0...575V 3-Phase Output | | | | | | | | | |
| 25A-E0P9N104 | 25B-E0P9N104 | 0.5 | 0.4 | 0.5 | 0.4 | 0.9 | 446...660 | 22.0 | A |
| 25A-E1P7N104 | 25B-E1P7N104 | 1.0 | 0.75 | 1.0 | 0.75 | 1.7 | 446...660 | 32.0 | A |
| 25A-E3P0N104 | 25B-E3P0N104 | 2.0 | 1.5 | 2.0 | 1.5 | 3.0 | 446...660 | 50.0 | A |
| 25A-E4P2N104 | 25B-E4P2N104 | 3.0 | 2.2 | 3.0 | 2.2 | 4.2 | 446...660 | 65.0 | A |
| 25A-E6P6N104 | 25B-E6P6N104 | 5.0 | 4.0 | 5.0 | 4.0 | 6.6 | 446...660 | 95.0 | B |
| 25A-E9P9N104 | 25B-E9P9N104 | 7.5 | 5.5 | 7.5 | 5.5 | 9.9 | 446...660 | 138.0 | C |
| 25A-E012N104 | 25B-E012N104 | 10.0 | 7.5 | 10.0 | 7.5 | 12.0 | 446...660 | 164.0 | C |
| 25A-E019N104 | 25B-E019N104 | 15.0 | 11.0 | 15.0 | 11.0 | 19.0 | 446...660 | 290.0 | D |
| 25A-E022N104 | 25B-E022N104 | 20.0 | 15.0 | 15.0 | 11.0 | 22.0 | 446...660 | 336.0 | D |
| 25A-E027N104 | 25B-E027N104 | 25.0 | 18.5 | 20.0 | 15.0 | 27.0 | 446...660 | 466.0 | E |
| 25A-E032N104 | 25B-E032N104 | 30.0 | 22.0 | 25.0 | 18.5 | 32.0 | 446...660 | 562.0 | E |

(1) A non-filtered drive is not available for 380...480V AC 25 HP (18.5 kW) and 30 HP (22.0 kW) ratings. Filtered drives are available, however you must verify that the application will support a filtered drive

Drive Dimensions and Weight

Dimensions are in mm and (in.). Weights are in kg and (lb).

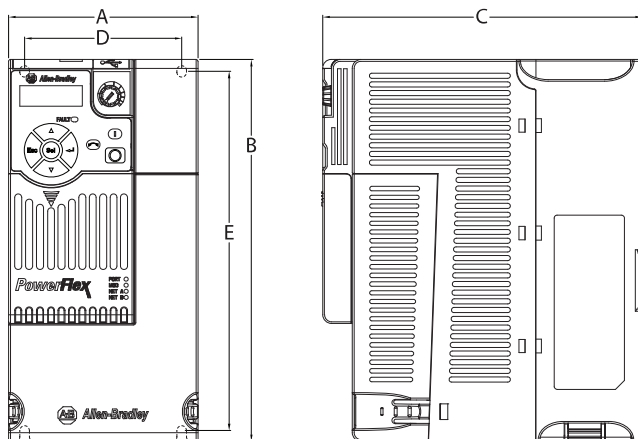

| Frame Size | A | B | C | D | E | Weight |
|------------|--------------|---------------|---------------|--------------|---------------|-------------|
| A | 72.0 (2.83) | 152.0 (5.98) | 172.0 (6.77) | 57.5 (2.26) | 140.0 (5.51) | 1.1 (2.4) |
| B | 87.0 (3.43) | 180.0 (7.09) | 172.0 (6.77) | 72.5 (2.85) | 168.0 (6.61) | 1.6 (3.5) |
| C | 109.0 (4.29) | 220.0 (8.66) | 184.0 (7.24) | 90.5 (3.56) | 207.0 (8.15) | 2.3 (5.0) |
| D | 130.0 (5.12) | 260.0 (10.24) | 212.0 (8.35) | 116.0 (4.57) | 247.0 (9.72) | 3.9 (8.6) |
| E | 185.0 (7.28) | 300.0 (11.81) | 279.0 (10.98) | 160.0 (6.30) | 280.0 (11.02) | 12.9 (28.4) |

Design Considerations

Mounting Considerations

- Mount the drive upright on a flat, vertical, and level surface.

| Frame | Screw Size | Screw Torque |
|-------|---------------|----------------------------------|
| A | M5 (#10...24) | 1.56...1.96 N•m (14...17 lb•in.) |
| B | M5 (#10...24) | 1.56...1.96 N•m (14...17 lb•in.) |
| C | M5 (#10...24) | 1.56...1.96 N•m (14...17 lb•in.) |
| D | M5 (#10...24) | 2.45...2.94 N•m (22...26 lb•in.) |
| E | M8 (5/16 in.) | 6.0...7.4 N•m (53...65 lb•in.) |

- Protect the cooling fan by avoiding dust or metallic particles.
- Do not expose to a corrosive atmosphere.
- Protect from moisture and direct sunlight.

Minimum Mounting Clearances

See [Product Selection on page 14](#) for mounting dimensions.

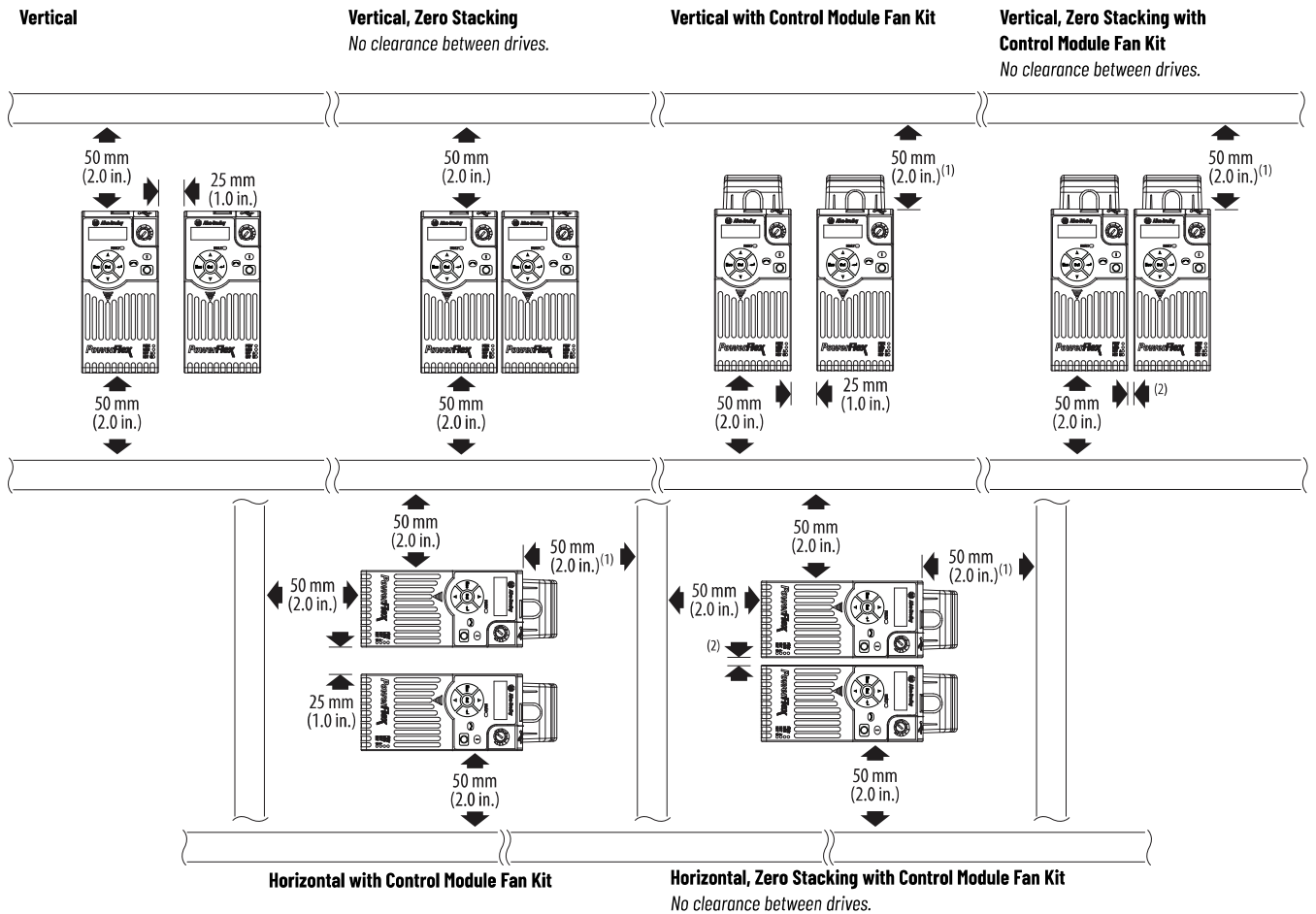

(1) For Frame E with Control Module Fan Kit only, clearance of 95 mm (3.7 in.) is required.

(2) For Frame E with Control Module Fan Kit only, clearance of 12 mm (0.5 in.) is required.

Ambient Operating Temperatures

For optional accessories and kits, see [Accessories and Dimensions on page 31](#).

| Mounting | Enclosure Rating ⁽¹⁾ | Ambient Temperature | | | |
|---|---------------------------------|---------------------|-----------------|-----------------------------|--|
| | | Min | Max (No Derate) | Max (Derate) ⁽²⁾ | Max with Control Module Fan Kit (Derate) ⁽³⁾⁽⁴⁾ |
| Vertical | IP 20/Open Type | -20 °C (-4 °F) | 50 °C (122 °F) | 60 °C (140 °F) | 70 °C (158 °F) |
| | IP 30/NEMA 1/UL Type 1 | | 45 °C (113 °F) | 55 °C (131 °F) | - |
| Vertical, Zero Stacking | IP 20/Open Type | | 45 °C (113 °F) | 55 °C (131 °F) | 65 °C (149 °F) |
| | IP 30/NEMA 1/UL Type 1 | | 40 °C (104 °F) | 50 °C (122 °F) | - |
| Horizontal with Control Module Fan Kit ⁽⁵⁾⁽⁴⁾ | IP 20/Open Type | | 50 °C (122 °F) | - | 70 °C (158 °F) |
| Horizontal, Zero Stacking with Control Module Fan Kit ⁽⁴⁾⁽⁵⁾ | IP 20/Open Type | 45 °C (113 °F) | - | 65 °C (149 °F) | |

- (1) IP 30/NEMA 1/UL Type 1 rating requires installation of the PowerFlex 520-Series IP 30/NEMA 1/UL Type 1 option kit, catalog number 25-JBAX.
- (2) IP 30/NEMA 1/UL Type 1 rating requires installation of the PowerFlex 520-Series IP 30/NEMA 1/UL Type 1 option kit, catalog number 25-JBAX.
- (3) For catalogs 25x-D1P4N104 and 25x-E0P9N104, the temperature listed under the Max. with Control Module Fan Kit (Derate) column is reduced by 10 °C (18 °F) for vertical and vertical with zero stacking mounting methods only.
- (4) Requires installation of the PowerFlex 520-Series Control Module Fan Kit, catalog number 25-FANx-70C.
- (5) Catalogs 25x-D1P4N104 and 25x-E0P9N104 cannot be mounted using either of the horizontal mounting methods.

Current Derating Curves

Vertical Mounting

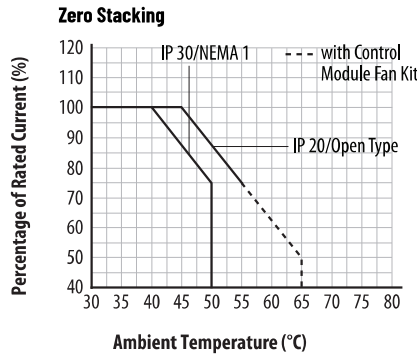
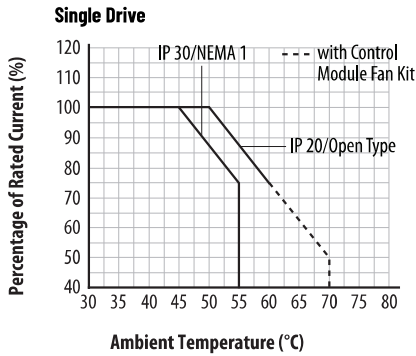

Horizontal Mounting/Floor

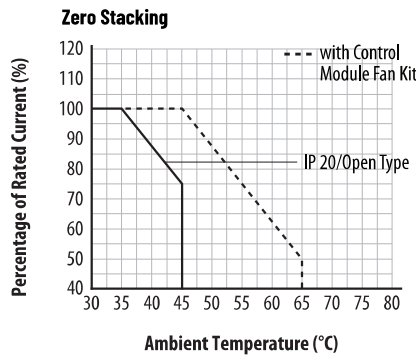
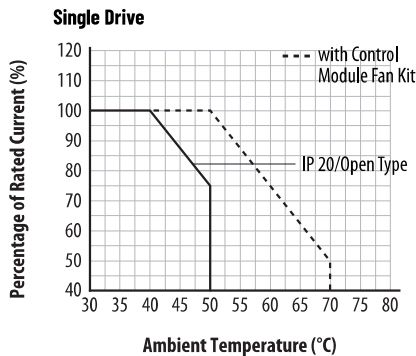

Derating Guidelines for High Altitude

The drive can be used without derating at a maximum altitude of 1000 m (3300 ft).

If the drive is used above 1000 m (3300 ft):

- Derate the maximum ambient temperature by 5 °C (9 °F) for every additional 1000 m (3300 ft), subject to limits listed in the Altitude Limit (Based on Voltage) table below.

Or

- Derate the output current by 10% for every additional 1000 m (3300 ft), subject to limits listed in the Altitude Limit (Based on Voltage) table below.

Altitude Limit (Based on Voltage)

| Drive Rating | Center Ground (Wye Neutral) | Corner Ground, Impedance Ground, or Ungrounded |
|--------------------|-----------------------------|--|
| 100...120V 1-Phase | 6000 m | 6000 m |
| 200...240V 1-Phase | 2000 m | 2000 m |
| 200...240V 3-Phase | 6000 m | 2000 m |
| 380...480V 3-Phase | 4000 m | 2000 m |
| 525...600V 3-Phase | 2000 m | 2000 m |

High Altitude

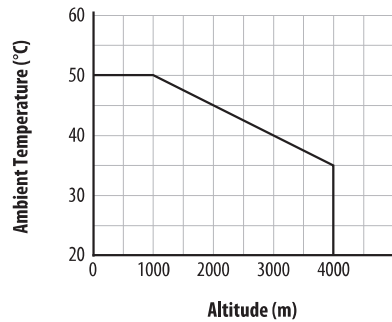
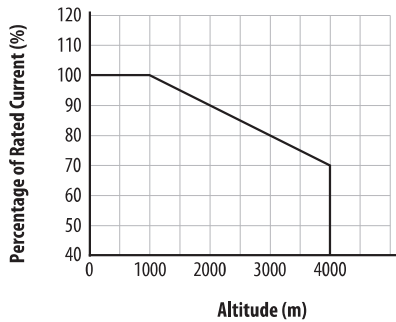

Debris Protection

Take precautions to prevent debris from falling through the vents of the drive housing during installation.

Storage

- Store within an ambient temperature range of -40...85 °C^(a).
- Store within a relative humidity range of 0...95%, noncondensing.
- Do not expose to a corrosive atmosphere.

(a) The maximum ambient temperature for storing a Frame E drive is 70 °C.

AC Supply Source Considerations

Ungrounded Distribution Systems



ATTENTION: PowerFlex 520-Series drives contain protective MOVs that are referenced to ground. These devices must be disconnected if the drive is installed on an ungrounded or resistive grounded distribution system.

ATTENTION: Removing MOVs in drives with an embedded filter will also disconnect the filter capacitor from earth ground.

Disconnecting MOVs

To prevent drive damage, the MOVs connected to ground shall be disconnected if the drive is installed on an ungrounded distribution system (IT mains) where the line-to-ground voltages on any phase could exceed 125% of the nominal line-to-line voltage. To disconnect these devices, remove the jumper shown in the diagrams below.

1. Turn the screw counterclockwise to loosen.
2. Pull the jumper completely out of the drive chassis.
3. Tighten the screw to keep it in place.

Jumper Location (Typical)

Power Module

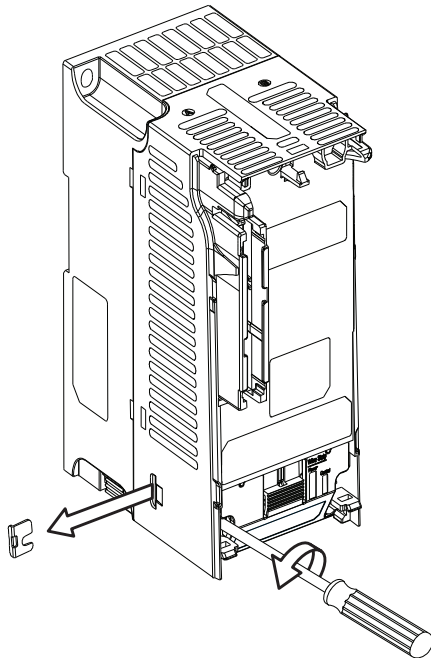

IMPORTANT Tighten screw after jumper removal.

Phase to Ground MOV Removal

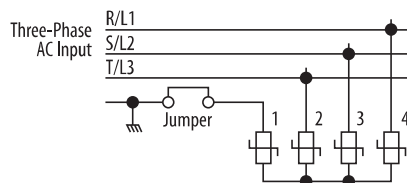

Input Power Conditioning

The drive is suitable for direct connection to input power within the rated voltage of the drive. See [Input Power Conditions on page 20](#).

Listed in the Input Power Conditions table below are certain input power conditions which may cause component damage or reduction in product life. If any of these conditions exist, install one of the devices listed under the heading Corrective Action on the line side of the drive.

IMPORTANT Only one device per branch circuit is required. It should be mounted closest to the branch and sized to handle the total current of the branch circuit.

Input Power Conditions

| Input Power Condition | Corrective Action |
|---|--|
| Low Line Impedance (less than 1% line reactance) | <ul style="list-style-type: none"> • Install Line Reactor⁽¹⁾ • or Isolation Transformer |
| Greater than 120 kVA supply transformer | |
| Line has power factor correction capacitors | <ul style="list-style-type: none"> • Install Line Reactor⁽¹⁾ • or Isolation Transformer |
| Line has frequent power interruptions | |
| Line has intermittent noise spikes in excess of 6000V (lightning) | |
| Phase to ground voltage exceeds 125% of normal line to line voltage | <ul style="list-style-type: none"> • Remove MOV jumper to ground. • or Install Isolation Transformer with grounded secondary if necessary. |
| Ungrounded distribution system | |
| B-phase grounded distribution system | |
| 240V open delta configuration (stinger leg) ⁽²⁾ | <ul style="list-style-type: none"> • Install Line Reactor⁽¹⁾ |

(1) See [Accessories and Dimensions on page 31](#) for accessory ordering information.

(2) For drives applied on an open delta with a middle phase grounded neutral system, the phase opposite the phase that is tapped in the middle to the neutral or earth is referred to as the "stinger leg," "high leg," "red leg," etc. This leg should be identified throughout the system with red or orange tape on the wire at each connection point. The stinger leg should be connected to the center Phase B on the reactor. See [Bulletin 1321-3R Series Line Reactors on page 37](#) for specific line reactor part numbers.

General Grounding Requirements

The drive Safety Ground - (PE) must be connected to system ground. Ground impedance must conform to the requirements of national and local industrial safety regulations and/or electrical codes. The integrity of all ground connections should be periodically checked.

Typical Grounding

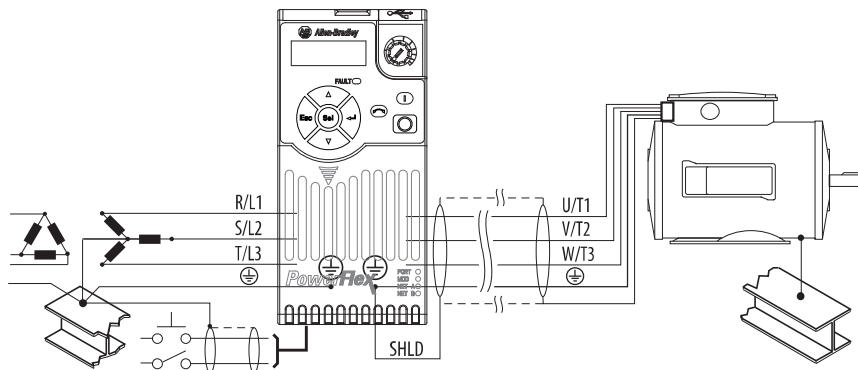

Ground Fault Monitoring

If a system ground fault monitor (RCD) is to be used, only Type B (adjustable) devices should be used to avoid nuisance tripping.

Safety Ground - \oplus (PE)

This is the safety ground for the drive that is required by code. One of these points must be connected to adjacent building steel (girder, joist), a floor ground rod or bus bar. Grounding points must comply with national and local industrial safety regulations and/or electrical codes.

Motor Ground

The motor ground must be connected to one of the ground terminals on the drive.

Shield Termination - SHLD

Either of the safety ground terminals located on the power terminal block provides a grounding point for the motor cable shield. The **motor cable** shield connected to one of these terminals (drive end) should also be connected to the motor frame (motor end). Use a shield terminating or EMI clamp to connect the shield to the safety ground terminal. The earthing plate or conduit box option may be used with a cable clamp for a grounding point for the cable shield.

When shielded cable is used for **control and signal wiring**, the shield should be grounded at the source end only, not at the drive end.

RFI Filter Grounding

Using a drive with filter may result in relatively high ground leakage currents. Therefore, the **filter must only be used in installations with grounded AC supply systems and be permanently installed and solidly grounded** (bonded) to the building power distribution ground. Ensure that the incoming supply neutral is solidly connected (bonded) to the same building power distribution ground. Grounding must not rely on flexible cables and should not include any form of plug or socket that would permit inadvertent disconnection. Some local codes may require redundant ground connections. The integrity of all connections should be periodically checked.

Power Wiring



ATTENTION: National Codes and standards (NEC, VDE, BSI, etc.) and local codes outline provisions for safely installing electrical equipment. Installation must comply with specifications regarding wire types, conductor sizes, branch circuit protection and disconnect devices. Failure to do so may result in personal injury and/or equipment damage.

ATTENTION: To avoid a possible shock hazard caused by induced voltages, unused wires in the conduit must be grounded at both ends. For the same reason, if a drive sharing a conduit is being serviced or installed, all drives using this conduit should be disabled. This will help minimize the possible shock hazard from "cross coupled" power leads.

Motor Cable Types Acceptable for 100...600 Volt Installations

A variety of cable types are acceptable for drive installations. For many installations, unshielded cable is adequate, provided it can be separated from sensitive circuits. As an approximate guide, allow a spacing of 0.3 m (1 ft) for every 10 m (32.8 ft) of length. In all cases, long parallel runs must be avoided. Do not use cable with an insulation thickness less than 15 mils (0.4 mm/0.015 in.). Do not route more than three sets of motor leads in a single conduit to minimize "cross talk". If more than three drive/motor connections per conduit are required, shielded cable must be used.

UL installations above 50 °C ambient must use 600V, 90 °C wire.

UL installations in 50 °C ambient must use 600V, 75 °C or 90 °C wire.

UL installations in 40 °C ambient should use 600V, 75 °C or 90 °C wire.

Use copper wire only. Wire gauge requirements and recommendations are based on 75 °C. Do not reduce wire gauge when using higher temperature wire.

Unshielded

THHN, THWN or similar wire is acceptable for drive installation in dry environments provided adequate free air space and/or conduit fill rates limits are provided. Any wire chosen must have a minimum insulation thickness of 15 mils and should not have large variations in insulation concentricity.



ATTENTION: Do not use THHN or similarly coated wire in wet areas.

Shielded/Armored Cable

Shielded cable contains all of the general benefits of multi-conductor cable with the added benefit of a copper braided shield that can contain much of the noise generated by a typical AC Drive. Strong consideration for shielded cable should be given in installations with sensitive equipment such as weigh scales, capacitive proximity switches and other devices that may be affected by electrical noise in the distribution system. Applications with large numbers of drives in a similar location, imposed EMC regulations or a high degree of communications / networking are also good candidates for shielded cable.

Shielded cable may also help reduce shaft voltage and induced bearing currents for some applications. In addition, the increased impedance of shielded cable may help extend the distance that the motor can be located from the drive without the addition of motor protective devices such as terminator networks. See Reflected Wave in "Wiring and Grounding Guide, (PWM) AC Drives," publication [DRIVES-IN001](#).

Consideration should be given to all of the general specifications dictated by the environment of the installation, including temperature, flexibility, moisture characteristics and chemical resistance. In addition, a braided shield should be included and be specified by the cable manufacturer as having coverage of at least 75%. An additional foil shield can greatly improve noise containment.

A good example of recommended cable is Belden 295xx (xx determines gauge). This cable has four XLPE insulated conductors with a 100% coverage foil and an 85% coverage copper braided shield (with drain wire) surrounded by a PVC jacket.

Other types of shielded cable are available, but the selection of these types may limit the allowable cable length. Particularly, some of the newer cables twist 4 conductors of THHN wire and wrap them tightly with a foil shield. This construction can greatly increase the cable charging current required and reduce the overall drive performance. Unless specified in the individual distance tables as tested with the drive, these cables are not recommended and their performance against the lead length limits supplied is not known.

Recommended Shielded Wire

| Location | Rating/Type | Description |
|----------------------------------|--|---|
| Standard (Option 1) | 600V, 90 °C (194 °F) XHHW2/RHW-2 Anixter B209500-B209507, Belden 29501-29507, or equivalent | <ul style="list-style-type: none"> Four tinned copper conductors with XLPE insulation. Copper braid/aluminum foil combination shield and tinned copper drain wire. PVC jacket. |
| Standard (Option 2) | Tray rated 600V, 90 °C (194 °F) RHH/RHW-2 Anixter 0LF-7xxxx or equivalent | <ul style="list-style-type: none"> Three tinned copper conductors with XLPE insulation. 5 mil single helical copper tape (25% overlap min) with three bare copper grounds in contact with shield. PVC jacket. |
| Class I & II; Division I & II | Tray rated 600V, 90 °C (194 °F) RHH/RHW-2 Anixter 7V-7xxxx-3G or equivalent | <ul style="list-style-type: none"> Three bare copper conductors with XLPE insulation and impervious corrugated continuously welded aluminum armor. Black sunlight resistant PVC jacket overall. Three copper grounds on #10 AWG and smaller. |

Reflected Wave Protection

The drive should be installed as close to the motor as possible. Installations with long motor cables may require the addition of external devices to limit voltage reflections at the motor (reflected wave phenomena). See Reflected Wave in "Wiring and Grounding Guide, (PWM) AC Drives," publication [DRIVES-IN001](#).

The reflected wave data applies to all carrier frequencies 2...16 kHz.

For 240V ratings and lower, reflected wave effects do not need to be considered.

Output Disconnect

The drive is intended to be commanded by control input signals that will start and stop the motor. A device that routinely disconnects then reapplies output power to the motor for the purpose of starting and stopping the motor should not be used. If it is necessary to disconnect power to the motor with the drive outputting power, an auxiliary contact should be used to simultaneously disable drive (Aux Fault or Coast-to-Stop).

Power Terminal Block Wire Specifications

| Frame | Wire Size max ⁽¹⁾ | Wire Size min ⁽¹⁾ | Torque |
|-------|------------------------------|------------------------------|--------------------------------------|
| A | 5.3 mm ² (10 AWG) | 0.8 mm ² (18 AWG) | 1.76...2.16 N•m (15.6...19.1 lb•in.) |
| B | 8.4 mm ² (8 AWG) | 2.1 mm ² (14 AWG) | 1.76...2.16 N•m (15.6...19.1 lb•in.) |
| C | 8.4 mm ² (8 AWG) | 2.1 mm ² (14 AWG) | 1.76...2.16 N•m (15.6...19.1 lb•in.) |
| D | 13.3 mm ² (6 AWG) | 5.3 mm ² (10 AWG) | 1.76...2.16 N•m (15.6...19.1 lb•in.) |
| E | 26.7 mm ² (3 AWG) | 8.4 mm ² (8 AWG) | 3.09...3.77 N•m (27.3...33.4 lb•in.) |

(1) Maximum/minimum sizes that the terminal block will accept – these are not recommendations.

Common Bus/Precharge Notes

If drives are used with a disconnect switch to the common DC bus, then an auxiliary contact on the disconnect must be connected to a digital input of the drive.

I/O Wiring

Motor Start/Stop Precautions



ATTENTION: A contactor or other device that routinely disconnects and reapplies the AC line to the drive to start and stop the motor can cause drive hardware damage. The drive is designed to use control input signals that will start and stop the motor. If used, the input device must not exceed one operation per minute or drive damage can occur.

ATTENTION: The drive start/stop control circuitry includes solid-state components. If hazards due to accidental contact with moving machinery or unintentional flow of liquid, gas or solids exist, an additional hardwired stop circuit may be required to remove the AC line to the drive. When the AC line is removed, there will be a loss of any inherent regenerative braking effect that might be present - the motor will coast to a stop. An auxiliary braking method may be required. Alternatively, use the drive's safety input function.

Important points to remember about I/O wiring:

- Always use copper wire.
- Wire with an insulation rating of 600V or greater is recommended.
- Control and signal wires should be separated from power wires by at least 0.3 m (1 ft).

IMPORTANT I/O terminals labeled "Common" are not referenced to the safety ground (PE) terminal and are designed to greatly reduce common mode interference.



ATTENTION: Driving the 4...20 mA analog input from a voltage source could cause component damage. Verify proper configuration prior to applying input signals.

Signal and Control Wire Types

Recommendations are for 50 °C ambient temperature.
 75 °C wire must be used for 60 °C ambient temperature.
 90 °C wire must be used for 70 °C ambient temperature.

Recommended Signal Wire

| Signal Type/Where Used | Belden Wire Type (or equivalent) ⁽¹⁾ | Description | Insulation Rating min |
|------------------------|---|---|-------------------------|
| Analog I/O and PTC | 8760/9460 | 0.750 mm ² (18 AWG), twisted pair, 100% shield with drain ⁽²⁾ | 300V, 60 °C (140 °F) |
| Remote Pot | 8770 | 0.750 mm ² (18 AWG), 3 conductor, shielded | |
| Encoder/Pulse I/O | 9728/9730 | 0.196 mm ² (24 AWG), individually shielded pairs | |

(1) Stranded or solid wire.

(2) If the wires are short and contained within a cabinet which has no sensitive circuits, the use of shielded wire may not be necessary, but is always recommended.

Recommended Control Wire for Digital I/O

| Type | Wire Type(s) | Description | Min. Insulation Rating |
|------------|--|--|-------------------------|
| Unshielded | Per US NEC or applicable national or local code | - | 300V, 60 °C (140 °F) |
| Shielded | Multi-conductor shielded cable such as Belden 8770 (or equivalent) | 0.750 mm ² (18 AWG), 3 conductor, shielded. | |

Maximum Control Wire Recommendation

Do not exceed control wiring length of 30 m (100 ft). Control signal cable length is highly dependent on electrical environment and installation practices. To improve noise immunity, the I/O terminal block Common may be connected to ground terminal/protective earth. If using the RS-485 (DSI) port, I/O Terminal C1 should also be connected to ground terminal/protective earth. Additionally, communication noise immunity can also be improved by connecting I/O Terminal C2 to ground terminal/protective earth.

Control I/O Terminal Block Wire Specifications

| Frame | Wire Size max ⁽¹⁾ | Wire Size min ⁽¹⁾ | Torque |
|-------|------------------------------|-------------------------------|------------------------------------|
| A...E | 1.3 mm ² (16 AWG) | 0.13 mm ² (26 AWG) | 0.71...0.86 N•m (6.2...7.6 lb•in.) |

(1) Maximum/minimum sizes that the terminal block will accept – these are not recommendations.

Machinery Directive (2006/42/EC)

- EN ISO 13849-1 – Safety of machinery – Safety related parts of control systems -Part 1: General principles for design.
- EN 62061 – Safety of machinery – Functional safety of safety-related electrical, electronic, and programmable electronic control systems.
- EN 60204-1 – Safety of machinery – Electrical equipment of machines - Part 1: General requirements.
- EN 61800-5-2 – Adjustable speed electrical power drive systems - Part 5-2: Safety requirement – Functional.

Connections and Grounding

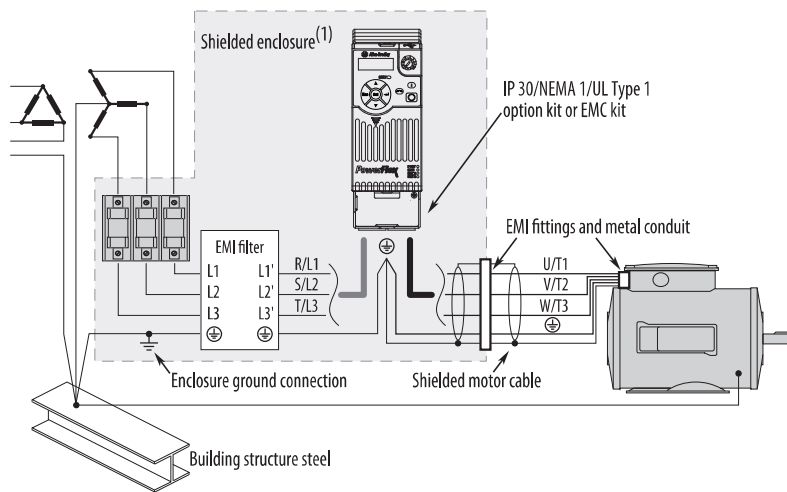

(1) Some installations require a shielded enclosure. Keep wire length as short as possible between the enclosure entry point and the EMI filter.

PowerFlex 520-Series RF Emission Compliance and Installation Requirements

| Filter Type | Standard/Limits | | |
|-------------------------|---|---|--|
| | EN61800-3 Category C1 EN61000-6-3 CISPR11 Group 1 Class B | EN61800-3 Category C2 EN61000-6-4 CISPR11 Group 1 Class A (Input power ≤ 20 kVA) | EN61800-3 Category C3 (I ≤ 100 A) CISPR11 Group 1 Class A (Input power > 20 kVA) |
| Internal | – | 10 m (33 ft) | 20 m (66 ft) |
| External ⁽¹⁾ | 30 m (16 ft) | 100 m (328 ft) | 100 m (328 ft) |

(1) See [EMC Line Filters on page 32](#) and [page 41](#) for more information on optional external filters.

Fuses and Circuit Breaker Ratings

The PowerFlex 520-Series drive does not provide branch short circuit protection. This product should be installed with either input fuses or an input circuit breaker. National and local industrial safety regulations and/or electrical codes may determine additional requirements for these installations.

The tables on pages [27...30](#) provide drive ratings and recommended AC line input fuse and circuit breaker information. Both types of short circuit protection are acceptable for UL and IEC requirements. Sizes listed are the recommended sizes based on 40 °C (104 °F) and the U.S. N.E.C. Other country, state or local codes may require different ratings.

Fusing

The recommended fuse types are listed in the tables found on pages [27...30](#). If available current ratings do not match those listed in the tables provided, choose the next higher fuse rating.

- IEC – BS88 (British Standard) Parts 1 & 2^(a), EN60269-1, Parts 1 & 2, type GG or equivalent should be used.
- UL – UL Class CC, T, RK1, or J should be used.

Circuit Breakers

The “non-fuse” listings in the tables found on pages [27...30](#) include inverse time circuit breakers, instantaneous trip circuit breakers (motor circuit protectors) and 140M self-protected combination motor controllers. If one of these is chosen as the desired protection method, the following requirements apply:

- IEC – Both types of circuit breakers and 140M self-protected combination motor controllers are acceptable for IEC installations.
- UL – Only inverse time circuit breakers and the specified 140M self-protected combination motor controllers are acceptable for UL installations.

Bulletin 140M (Self-Protected Combination Controller)/UL489 Circuit Breakers

When using Bulletin 140M or UL489 rated circuit breakers, the guidelines listed below must be followed in order to meet the NEC requirements for branch circuit protection.

- Bulletin 140M can be used in single motor applications.
- Bulletin 140M can be used up stream from the drive **without** the need for fuses.

(a) Typical designations include, but may not be limited to the following:
Parts 1 & 2: AC, AD, BC, BD, CD, DD, ED, EFS, EF, FF, FG, GF, GG, GH

Fuses and Circuit Breakers for PowerFlex 520-Series Drives

100...120V 1-Phase Input Protection Devices – Frames A...B

| Catalog No. | Output Ratings | | | | | | Input Ratings | | | IEC Applications (Non-UL) | | | UL Applications | | | | | |
|--------------|----------------|------|------|------|------|-------------------------|---------------|-------------|----------------|---------------------------|------------------|------|---------------------|------------------|-----------------------------------|---|---------------------|-----------|
| | ND | HD | | kVA | Amps | Max Amps ⁽¹⁾ | Frame Size | Catalog No. | Fuses (Rating) | | Circuit Breakers | | Fuses (Max. Rating) | Circuit Breakers | | Min. Enclosure Vol. (in. ³) | | |
| | | HP | kW | | | | | | HP | kW | Min. | Max. | | 140U/140G | 140M | | Class / Catalog No. | 140U/140G |
| PF 523 | PF 525 | | | | | | | | | | | | | | | | | |
| 25A-V1P6N104 | - | 0.25 | 0.2 | 0.25 | 0.2 | 1.6 | 0.8 | 6.4 | A | 100-C09 | 10 | 16 | 140M-C2E-B63 | 140M-C2E-B63 | CLASS RK5, CC, J, or T / DLS-R-15 | 140U-D6D2-B80 | 140M-C2E-B63 | - |
| 25A-V2P5N104 | 25B-V2P5N104 | 0.5 | 0.4 | 0.5 | 0.4 | 2.5 | 1.3 | 9.6 | A | 100-C12 | 16 | 20 | 140M-C2E-C10 | 140M-C2E-C10 | CLASS RK5, CC, J, or T / DLS-R-20 | 140U-D6C2-C12 | 140M-C2E-C10 | - |
| 25A-V4P8N104 | 25B-V4P8N104 | 1.0 | 0.75 | 1.0 | 0.75 | 4.8 | 2.5 | 19.2 | B | 100-C23 | 25 | 40 | 140M-D8E-C20 | 140M-D8E-C20 | CLASS RK5, CC, J, or T / DLS-R-40 | 140U-D6D2-C25 | 140M-D8E-C20 | - |
| 25A-V6P0N104 | 25B-V6P0N104 | 1.5 | 1.1 | 1.5 | 1.1 | 6.0 | 3.2 | 24.0 | B | 100-C23 | 32 | 50 | 140M-F8E-C25 | 140M-F8E-C25 | CLASS RK5, CC, J, or T / DLS-R-50 | 140U-D6D2-C30 | 140M-F8E-C25 | - |

200...240V 1-Phase Input Protection Devices – Frames A...B

| Catalog No. | Output Ratings | | | | | | Input Ratings | | | IEC Applications (Non-UL) | | | UL Applications | | | | | |
|--------------|----------------|------|------|------|------|-------------------------|---------------|-------------|----------------|---------------------------|------------------|------|---------------------|------------------|-----------------------------------|---|---------------------|-----------|
| | ND | HD | | kVA | Amps | Max Amps ⁽¹⁾ | Frame Size | Catalog No. | Fuses (Rating) | | Circuit Breakers | | Fuses (Max. Rating) | Circuit Breakers | | Min. Enclosure Vol. (in. ³) | | |
| | | HP | kW | | | | | | HP | kW | Min. | Max. | | 140U/140G | 140M | | Class / Catalog No. | 140U/140G |
| PF 523 | PF 525 | | | | | | | | | | | | | | | | | |
| 25A-A1P6N104 | - | 0.25 | 0.2 | 0.25 | 0.2 | 1.6 | 1.4 | 5.3 | A | 100-C09 | 6 | 10 | 140M-C2E-B63 | 140M-C2E-B63 | CLASS RK5, CC, J, or T / DLS-R-15 | 140U-D6D2-C10 | 140M-C2E-B63 | - |
| 25A-A1P6N114 | - | 0.25 | 0.2 | 0.25 | 0.2 | 1.6 | 1.4 | 5.3 | A | 100-C09 | 6 | 10 | 140M-C2E-B63 | 140M-C2E-B63 | CLASS RK5, CC, J, or T / DLS-R-15 | 140U-D6D2-C10 | 140M-C2E-B63 | - |
| 25A-A2P5N104 | 25B-A2P5N104 | 0.5 | 0.4 | 0.5 | 0.4 | 2.5 | 1.7 | 6.5 | A | 100-C09 | 10 | 16 | 140M-C2E-C10 | 140M-C2E-C10 | CLASS RK5, CC, J, or T / DLS-R-15 | 140U-D6D2-C10 | 140M-C2E-C10 | - |
| 25A-A2P5N114 | 25B-A2P5N114 | 0.5 | 0.4 | 0.5 | 0.4 | 2.5 | 1.7 | 6.5 | A | 100-C09 | 10 | 16 | 140M-C2E-C10 | 140M-C2E-C10 | CLASS RK5, CC, J, or T / DLS-R-15 | 140U-D6D2-C10 | 140M-C2E-C10 | - |
| 25A-A4P8N104 | 25B-A4P8N104 | 1.0 | 0.75 | 1.0 | 0.75 | 4.8 | 2.8 | 10.7 | A | 100-C12 | 16 | 25 | 140M-C2E-C16 | 140M-C2E-C16 | CLASS RK5, CC, J, or T / DLS-R-25 | 140U-D6D2-C15 | 140M-C2E-C16 | - |
| 25A-A4P8N114 | 25B-A4P8N114 | 1.0 | 0.75 | 1.0 | 0.75 | 4.8 | 2.8 | 10.7 | A | 100-C12 | 16 | 25 | 140M-C2E-C16 | 140M-C2E-C16 | CLASS RK5, CC, J, or T / DLS-R-25 | 140U-D6D2-C15 | 140M-C2E-C16 | - |
| 25A-A8P0N104 | 25B-A8P0N104 | 2.0 | 1.5 | 2.0 | 1.5 | 8.0 | 4.8 | 18.0 | B | 100-C23 | 25 | 40 | 140M-F8E-C25 | 140M-F8E-C25 | CLASS CC, J, or T / 40 | 140U-D6D2-C25 | 140M-F8E-C25 | - |
| 25A-A8P0N114 | 25B-A8P0N114 | 2.0 | 1.5 | 2.0 | 1.5 | 8.0 | 4.8 | 18.0 | B | 100-C23 | 25 | 40 | 140M-F8E-C25 | 140M-F8E-C25 | CLASS CC, J, or T / 40 | 140U-D6D2-C25 | 140M-F8E-C25 | - |
| 25A-A011N104 | 25B-A011N104 | 3.0 | 2.2 | 3.0 | 2.2 | 11.0 | 6.0 | 22.9 | B | 100-C37 | 32 | 50 | 140G-66C3-C35 | 140M-F8E-C25 | CLASS CC, J, or T / 50 | _(6) | 140M-F8E-C25 | - |
| 25A-A011N114 | 25B-A011N114 | 3.0 | 2.2 | 3.0 | 2.2 | 11.0 | 6.0 | 22.9 | B | 100-C37 | 32 | 50 | 140G-66C3-C35 | 140M-F8E-C25 | CLASS CC, J, or T / 50 | _(5) | 140M-F8E-C25 | - |

- (1) When the drive is controlling motors with lower amp ratings, refer to the drive nameplate for drive input current rating.
- (2) The AIC ratings of the Bulletin 140M Motor Protector Circuit Breakers may vary. See the Use of Motor Protection Circuit Breakers with Variable-Frequency Drives Application Techniques, publication [140M-AI002](#).
- (3) Bulletin 140M with adjustable current range should have the current trip set to the minimum range that the device will not trip.
- (4) Manual Self-Protected (Type E) Combination Motor Controller, UL Listed for 480V/277 and 600V/347 AC input. Not UL Listed for use on 480V or 600V Delta/Delta, corner ground, or high-resistance ground systems.
- (5) Circuit breaker selection is not available for this drive rating.

Fuses and Circuit Breakers for PowerFlex 520-Series Drives (continued)

200...240V 3-Phase Input Protection Devices – Frames A...E

| Catalog No. (1) | Output Ratings | | | | | | Input Ratings | | | Frame Size | Catalog No. | IEC Applications (Non-UL) | | | UL Applications | | | Min. Enclosure Vol. (in.³) |
|-----------------|----------------|--------|------|------|------|------|---------------|-------------|----------------|------------|-------------|---------------------------|---------------|---------------------|-----------------------------------|---------------|----------------------------|----------------------------|
| | PF 523 | PF 525 | ND | | HD | | kVA | Max Amps(2) | Fuses (Rating) | | | Circuit Breakers | | Fuses (Max. Rating) | Circuit Breakers | | Min. Enclosure Vol. (in.³) | |
| | | | HP | kW | HP | kW | | | | | | 140M | 140U/140G | | Class / Catalog No. | 140U/140G | | |
| 25A-B1P6N104 | - | 0.25 | 0.2 | 0.25 | 0.2 | 1.6 | 0.9 | 1.9 | A | 100-C09 | 3 | 6 | 140U-D6D3-B30 | 140M-C2E-B25 | CLASS RK5, CC, J, or T / DLS-R-15 | 140U-D6D3-B30 | 140M-C2E-B25 | - |
| 25A-B2P5N104 | 25B-B2P5N104 | 0.5 | 0.4 | 0.5 | 0.4 | 2.5 | 1.2 | 2.7 | A | 100-C09 | 6 | 6 | 140U-D6D3-B40 | 140M-C2E-B40 | CLASS RK5, CC, J, or T / DLS-R-6 | 140U-D6D3-B40 | 140M-C2E-B40 | - |
| 25A-B5P0N104 | 25B-B5P0N104 | 1.0 | 0.75 | 1.0 | 0.75 | 5.0 | 2.7 | 5.8 | A | 100-C09 | 10 | 16 | 140U-D6D3-B80 | 140M-C2E-B63 | CLASS RK5, CC, J, or T / DLS-R-15 | 140U-D6D3-B80 | 140M-C2E-B63 | - |
| 25A-B8P0N104 | 25B-B8P0N104 | 2.0 | 1.5 | 2.0 | 1.5 | 8.0 | 4.3 | 9.5 | A | 100-C12 | 16 | 20 | 140U-D6D3-C10 | 140M-C2E-C10 | CLASS RK5, CC, J, or T / DLS-R-20 | 140U-D6D3-C10 | 140M-C2E-C10 | - |
| 25A-B011N104 | 25B-B011N104 | 3.0 | 2.2 | 3.0 | 2.2 | 11.0 | 6.3 | 13.8 | A | 100-C23 | 20 | 32 | 140U-D6D3-C15 | 140M-C2E-C16 | CLASS RK5, CC, J, or T / DLS-R-30 | 140U-D6D3-C15 | 140M-C2E-C16 | - |
| 25A-B017N104 | 25B-B017N104 | 5.0 | 4.0 | 5.0 | 4.0 | 17.5 | 9.6 | 21.1 | B | 100-C23 | 32 | 45 | 140U-D6D3-C25 | 140M-F8E-C25 | CLASS CC, J, or T / 45 | 140U-D6D3-C25 | 140M-F8E-C25 | - |
| 25A-B024N104 | 25B-B024N104 | 7.5 | 5.5 | 7.5 | 5.5 | 24.0 | 12.2 | 26.6 | C | 100-C37 | 35 | 63 | 140G-G6C3-C35 | 140M-F8E-C32 | CLASS CC, J, or T / 60 | _ (7) | 140M-F8E-C32 | - |
| 25A-B032N104 | 25B-B032N104 | 10.0 | 7.5 | 10.0 | 7.5 | 32.2 | 15.9 | 34.8 | D | 100-C43 | 45 | 70 | 140G-G6C3-C60 | 140M-F8E-C45 | CLASS RK5, CC, J, or T / DLS-R-70 | _ (7) | 140M-F8E-C45 | - |
| 25A-B048N104 | 25B-B048N104 | 15.0 | 11.0 | 10.0 | 7.5 | 48.3 | 20.1 | 44.0 | E | 100-C60 | 63 | 90 | 140G-G6C3-C70 | 140M-F8E-C45 | CLASS CC, J, or T / 90 | _ (7) | 140M-F8E-C45 | 1416.0(6) |
| 25A-B062N104 | 25B-B062N104 | 20.0 | 15.0 | 15.0 | 11.0 | 62.1 | 25.6 | 56.0 | E | 100-C72 | 70 | 125 | 140G-G6C3-C90 | _ (7) | CLASS CC, J, or T / 125 | _ (7) | - | - |

- (1) ■ Normal and Heavy Duty ratings are available for this drive.
- (2) When the drive is controlling motors with lower amp ratings, refer to the drive nameplate for drive input current rating.
- (3) The AIC ratings of the Bulletin 140M Motor Protector Circuit Breakers may vary. See the Use of Motor Protection Circuit Breakers with Variable-Frequency Drives Application Techniques, publication [140M-AI002](#).
- (4) Bulletin 140M with adjustable current range should have the current trip set to the minimum range that the device will not trip.
- (5) Manual Self-Protected (Type E) Combination Motor Controller, UL Listed for 480Y/277 and 600Y/347 AC input. Not UL Listed for use on 480V or 600V Delta/Delta, corner ground, or high-resistance ground systems.
- (6) When using a Manual Self-Protected (Type E) Combination Motor Controller with this drive power rating, the drive must be installed in a ventilated or non-ventilated enclosure with the minimum volume specified in this column. Application specific thermal considerations may require a larger enclosure.
- (7) Circuit breaker selection is not available for this drive rating.

Fuses and Circuit Breakers for PowerFlex 520-Series Drives (continued)

380...480V 3-Phase Input Protection Devices – Frames A...E

| Catalog No. (1) | Output Ratings | | | | | | Input Ratings | | | Frame Size | Contactor No. | IEC Applications (Non-UL) | | | UL Applications | | | Min. Enclosure Vol. (in. 3) | | |
|-----------------|----------------|--------|------|------|------|------|---------------|---------|--------------|------------|---------------|---------------------------|--------------|-----------------------------------|-----------------|---------------------|--------------|-----------------------------|------------------|--|
| | PF 523 | PF 525 | ND | | HD | | Amps | kVA | Max Amps (2) | | | Fuses (Rating) | | Circuit Breakers | | Fuses (Max. Rating) | | | Circuit Breakers | |
| | | | HP | KW | HP | KW | | | | | | Min. | Max. | 140U/140G | 140M | Class / Catalog No. | 140M/140G | | 140M(3)X4(5) | |
| 25A-D1P4N104 | 0.5 | 0.4 | 0.5 | 0.4 | 1.4 | 1.9 | A | 100-C09 | 3 | 6 | 140M-C2E-B25 | 140U-D603-B30 | 140M-C2E-B25 | CLASS RK5, CC, J, or T / DLS-R-6 | 140M-C2E-B25 | (7) | 140M-C2E-B25 | - | | |
| 25A-D1P4N114 | 0.5 | 0.4 | 0.5 | 0.4 | 1.4 | 1.9 | A | 100-C09 | 3 | 6 | 140M-C2E-B25 | 140U-D603-B30 | 140M-C2E-B25 | CLASS RK5, CC, J, or T / DLS-R-6 | 140M-C2E-B25 | (7) | 140M-C2E-B25 | - | | |
| 25A-D2P3N104 | 1.0 | 0.75 | 1.0 | 0.75 | 2.3 | 3.2 | A | 100-C09 | 6 | 10 | 140M-C2E-B40 | 140U-D603-B60 | 140M-C2E-B40 | CLASS RK5, CC, J, or T / DLS-R-10 | 140M-C2E-B40 | (7) | 140M-C2E-B40 | - | | |
| 25A-D2P3N114 | 1.0 | 0.75 | 1.0 | 0.75 | 2.3 | 3.2 | A | 100-C09 | 6 | 10 | 140M-C2E-B40 | 140U-D603-B60 | 140M-C2E-B40 | CLASS RK5, CC, J, or T / DLS-R-10 | 140M-C2E-B40 | (7) | 140M-C2E-B40 | - | | |
| 25A-D4P0N104 | 2.0 | 1.5 | 2.0 | 1.5 | 4.0 | 5.7 | A | 100-C09 | 10 | 16 | 140M-C2E-B63 | 140U-D603-B60 | 140M-C2E-B63 | CLASS RK5, CC, J, or T / DLS-R-15 | 140M-C2E-B63 | (7) | 140M-C2E-B63 | - | | |
| 25A-D4P0N114 | 2.0 | 1.5 | 2.0 | 1.5 | 4.0 | 5.7 | A | 100-C09 | 10 | 16 | 140M-C2E-B63 | 140U-D603-B60 | 140M-C2E-B63 | CLASS RK5, CC, J, or T / DLS-R-15 | 140M-C2E-B63 | (7) | 140M-C2E-B63 | - | | |
| 25A-D6P0N104 | 3.0 | 2.2 | 3.0 | 2.2 | 6.0 | 7.5 | A | 100-C09 | 10 | 16 | 140M-C2E-C10 | 140U-D603-C10 | 140M-C2E-C10 | CLASS RK5, CC, J, or T / DLS-R-15 | 140M-C2E-C10 | (7) | 140M-C2E-C10 | - | | |
| 25A-D6P0N114 | 3.0 | 2.2 | 3.0 | 2.2 | 6.0 | 7.5 | A | 100-C09 | 10 | 16 | 140M-C2E-C10 | 140U-D603-C10 | 140M-C2E-C10 | CLASS RK5, CC, J, or T / DLS-R-15 | 140M-C2E-C10 | (7) | 140M-C2E-C10 | - | | |
| 25A-D010N104 | 5.0 | 4.0 | 5.0 | 4.0 | 10.5 | 13.8 | B | 100-C23 | 20 | 32 | 140M-C2E-C16 | 140U-D603-C15 | 140M-C2E-C16 | CLASS RK5, CC, J, or T / DLS-R-30 | 140M-D8E-C16 | (7) | 140M-D8E-C16 | - | | |
| 25A-D010N114 | 5.0 | 4.0 | 5.0 | 4.0 | 10.5 | 13.8 | B | 100-C23 | 20 | 32 | 140M-C2E-C16 | 140U-D603-C15 | 140M-C2E-C16 | CLASS RK5, CC, J, or T / DLS-R-30 | 140M-D8E-C16 | (7) | 140M-D8E-C16 | - | | |
| 25A-D013N104 | 7.5 | 5.5 | 7.5 | 5.5 | 13.0 | 14.1 | C | 100-C23 | 20 | 35 | 140M-D8E-C20 | 140U-D603-C25 | 140M-D8E-C20 | CLASS CC, J, or T / 35 | 140M-D8E-C20 | (7) | 140M-D8E-C20 | - | | |
| 25A-D013N114 | 7.5 | 5.5 | 7.5 | 5.5 | 13.0 | 14.1 | C | 100-C23 | 20 | 35 | 140M-D8E-C20 | 140U-D603-C25 | 140M-D8E-C20 | CLASS CC, J, or T / 35 | 140M-D8E-C20 | (7) | 140M-D8E-C20 | - | | |
| 25A-D017N104 | 10.0 | 7.5 | 10.0 | 7.5 | 17.0 | 18.4 | C | 100-C23 | 25 | 40 | 140M-D8E-C20 | 140U-D603-C25 | 140M-D8E-C20 | CLASS CC, J, or T / 40 | 140M-D8E-C20 | (7) | 140M-D8E-C20 | - | | |
| 25A-D017N114 | 10.0 | 7.5 | 10.0 | 7.5 | 17.0 | 18.4 | C | 100-C23 | 25 | 40 | 140M-D8E-C20 | 140U-D603-C25 | 140M-D8E-C20 | CLASS CC, J, or T / 40 | 140M-D8E-C20 | (7) | 140M-D8E-C20 | - | | |
| 25A-D024N104 | 15.0 | 11.0 | 15.0 | 11.0 | 24.0 | 26.4 | D | 100-C37 | 35 | 63 | 140M-F8E-C32 | 140G-66C3-C40 | 140M-F8E-C32 | CLASS CC, J, or T / 60 | 140M-F8E-C32 | (7) | 140M-F8E-C32 | 656.7(6) | | |
| 25A-D024N114 | 15.0 | 11.0 | 15.0 | 11.0 | 24.0 | 26.4 | D | 100-C37 | 35 | 63 | 140M-F8E-C32 | 140G-66C3-C40 | 140M-F8E-C32 | CLASS CC, J, or T / 60 | 140M-F8E-C32 | (7) | 140M-F8E-C32 | 656.7(6) | | |
| 25A-D030N104 | 20.0 | 15.0 | 20.0 | 15.0 | 30.0 | 33.0 | D | 100-C43 | 45 | 70 | 140M-F8E-C45 | 140G-66C3-C50 | 140M-F8E-C45 | CLASS CC, J, or T / 70 | 140M-F8E-C45 | (7) | 140M-F8E-C45 | 656.7(6) | | |
| 25A-D030N114 | 20.0 | 15.0 | 20.0 | 15.0 | 30.0 | 33.0 | D | 100-C43 | 45 | 70 | 140M-F8E-C45 | 140G-66C3-C50 | 140M-F8E-C45 | CLASS CC, J, or T / 70 | 140M-F8E-C45 | (7) | 140M-F8E-C45 | 656.7(6) | | |
| 25A-D037N114 | 25.0 | 18.5 | 20.0 | 15.0 | 37.0 | 33.7 | E | 100-C43 | 45 | 70 | 140M-F8E-C45 | 140G-66C3-C50 | 140M-F8E-C45 | CLASS CC, J, or T / 70 | 140M-F8E-C45 | (7) | 140M-F8E-C45 | - | | |
| 25A-D043N114 | 30.0 | 22.0 | 25.0 | 18.5 | 43.0 | 38.9 | E | 100-C60 | 50 | 80 | 140M-F8E-C45 | 140G-66C3-C60 | 140M-F8E-C45 | CLASS CC, J, or T / 80 | 140M-F8E-C45 | (7) | 140M-F8E-C45 | - | | |

(1) Normal and Heavy Duty ratings are available for this drive
 (2) When the drive is controlling motors with lower amp ratings, refer to the drive nameplate for drive input current rating.
 (3) The AIC ratings of the Bulletin 140M Motor Protector Circuit Breakers may vary. See the Use of Motor Protection Circuit Breakers with Variable-Frequency Drives Application Techniques, publication 140M-A1002.
 (4) Bulletin 140M with adjustable current range should have the current trip set to the minimum range that the device will not trip.
 (5) Manual Self-Protected (Type E) Combination Motor Controller, UL Listed for 480Y/277 and 600Y/347 AC input. Not UL Listed for use on 480V or 600V Delta/Delta, corner ground, or high-resistance ground systems.
 (6) When using a Manual Self-Protected (Type E) Combination Motor Controller with this drive power rating, the drive must be installed in a ventilated or non-ventilated enclosure with the minimum volume specified in this column. Application specific thermal considerations may require a larger enclosure.
 (7) Circuit breaker selection is not available for this drive rating.

Fuses and Circuit Breakers for PowerFlex 520-Series Drives (continued)
 525...600V 3-Phase Input Protection Devices – Frames A...E

| Catalog No. (1) | | Output Ratings | | | | Input Ratings | | | Frame Size | | Contactor No. | | IEC Applications (Non-UL) | | | UL Applications | | | Min. Enclosure Vol. (in.³) | | | | | |
|-----------------|--------------|----------------|------|------|------|---------------|------|------|--------------|---------|---------------|----|---------------------------|--------------|---------------|-----------------|-----------------------------------|--------------|----------------------------|---------------------|------------------|---------------------|----------------------------|-----------|
| PF 523 | PF 525 | ND | HP | kW | HP | kW | Amps | kVA | Max Amps (2) | A | B | C | D | E | Min. | Max. | Circuit Breakers | | Fuses (Max. Rating) | Class / Catalog No. | Circuit Breakers | Fuses (Max. Rating) | Min. Enclosure Vol. (in.³) | |
| | | | | | | | | | | | | | | | | | 140U/140G | 140M | | | | | | 140U/140G |
| 25A-E0P9N104 | 25B-E0P9N104 | 0.5 | 0.4 | 0.5 | 0.4 | 0.9 | 1.4 | 1.2 | 6 | 100-C09 | 3 | 6 | 140U-D603-B20 | 140M-C2E-B25 | 140U-D603-B20 | 140M-C2E-B25 | CLASS RK5, CC, J, or T / DLS-R-6 | 140M-C2E-B25 | 140M-C2E-B25 | 140M-C2E-B25 | 140M-C2E-B25 | 140M-C2E-B25 | 140M-C2E-B25 | - |
| 25A-E1P7N104 | 25B-E1P7N104 | 1.0 | 0.75 | 1.0 | 0.75 | 1.7 | 2.6 | 2.3 | 6 | 100-C09 | 3 | 6 | 140U-D603-B30 | 140M-C2E-B25 | 140U-D603-B30 | 140M-C2E-B25 | CLASS RK5, CC, J, or T / DLS-R-6 | 140M-C2E-B25 | 140M-C2E-B25 | 140M-C2E-B25 | 140M-C2E-B25 | 140M-C2E-B25 | 140M-C2E-B25 | - |
| 25A-E3P0N104 | 25B-E3P0N104 | 2.0 | 1.5 | 2.0 | 1.5 | 3.0 | 4.3 | 3.8 | 10 | 100-C09 | 6 | 10 | 140U-D603-B50 | 140M-C2E-B40 | 140U-D603-B50 | 140M-C2E-B40 | CLASS RK5, CC, J, or T / DLS-R-10 | 140M-C2E-B40 | 140M-C2E-B40 | 140M-C2E-B40 | 140M-C2E-B40 | 140M-C2E-B40 | 140M-C2E-B40 | - |
| 25A-E4P2N104 | 25B-E4P2N104 | 3.0 | 2.2 | 3.0 | 2.2 | 4.2 | 6.1 | 5.3 | 16 | 100-C09 | 10 | 16 | 140U-D603-B80 | 140M-C2E-B63 | 140U-D603-B80 | 140M-C2E-B63 | CLASS RK5, CC, J, or T / DLS-R-15 | 140M-C2E-B63 | 140M-C2E-B63 | 140M-C2E-B63 | 140M-C2E-B63 | 140M-C2E-B63 | 140M-C2E-B63 | - |
| 25A-E6P6N104 | 25B-E6P6N104 | 5.0 | 4.0 | 5.0 | 4.0 | 6.6 | 9.1 | 8.0 | 20 | 100-C09 | 10 | 20 | 140U-D603-C10 | 140M-C2E-C10 | 140U-D603-C10 | 140M-C2E-C10 | CLASS RK5, CC, J, or T / DLS-R-20 | 140M-C2E-C10 | 140M-C2E-C10 | 140M-C2E-C10 | 140M-C2E-C10 | 140M-C2E-C10 | 140M-C2E-C10 | - |
| 25A-E9P9N104 | 25B-E9P9N104 | 7.5 | 5.5 | 7.5 | 5.5 | 9.9 | 12.8 | 11.2 | 25 | 100-C16 | 16 | 25 | 140U-D603-C15 | 140M-C2E-C16 | 140U-D603-C15 | 140M-C2E-C16 | CLASS RK5, CC, J, or T / DLS-R-25 | 140M-C2E-C16 | 140M-C2E-C16 | 140M-C2E-C16 | 140M-C2E-C16 | 140M-C2E-C16 | 140M-C2E-C16 | - |
| 25A-E012N104 | 25B-E012N104 | 10.0 | 7.5 | 10.0 | 7.5 | 12.0 | 15.4 | 13.5 | 32 | 100-C23 | 20 | 32 | 140U-D603-C20 | 140M-C2E-C16 | 140U-D603-C20 | 140M-C2E-C16 | CLASS RK5, CC, J, or T / DLS-R-30 | 140M-C2E-C16 | 140M-C2E-C16 | 140M-C2E-C16 | 140M-C2E-C16 | 140M-C2E-C16 | 140M-C2E-C16 | - |
| 25A-E019N104 | 25B-E019N104 | 15.0 | 11.0 | 15.0 | 11.0 | 19.0 | 27.4 | 24.0 | 50 | 100-C30 | 32 | 50 | 140G-66C3-C30 | 140M-F8E-C25 | 140G-66C3-C30 | 140M-F8E-C25 | CLASS CC, J, or T / 50 | 140M-F8E-C25 | 140M-F8E-C25 | 140M-F8E-C25 | 140M-F8E-C25 | 140M-F8E-C25 | 656.7(7) | |
| 25A-E022N104 | 25B-E022N104 | 20.0 | 15.0 | 20.0 | 15.0 | 22.0 | 31.2 | 27.3 | 63 | 100-C30 | 35 | 63 | 140G-66C3-C35 | 140M-F8E-C32 | 140G-66C3-C35 | 140M-F8E-C32 | CLASS CC, J, or T / 60 | 140M-F8E-C32 | 140M-F8E-C32 | 140M-F8E-C32 | 140M-F8E-C32 | 140M-F8E-C32 | 656.7(7) | |
| 25A-E027N104 | 25B-E027N104 | 25.0 | 18.5 | 25.0 | 18.5 | 27.0 | 28.2 | 24.7 | 50 | 100-C30 | 35 | 50 | 140G-66C3-C35 | 140M-F8E-C32 | 140G-66C3-C35 | 140M-F8E-C32 | CLASS CC, J, or T / 50 | 140M-F8E-C32 | 140M-F8E-C32 | 140M-F8E-C32 | 140M-F8E-C32 | 140M-F8E-C32 | 1416.0(7) | |
| 25A-E032N104 | 25B-E032N104 | 30.0 | 22.0 | 30.0 | 22.0 | 32.0 | 33.4 | 29.2 | 63 | 100-C37 | 40 | 63 | 140G-66C3-C50 | 140M-F8E-C32 | 140G-66C3-C50 | 140M-F8E-C32 | CLASS CC, J, or T / 60 | 140M-F8E-C32 | 140M-F8E-C32 | 140M-F8E-C32 | 140M-F8E-C32 | 140M-F8E-C32 | 1416.0(7) | |

(1) Normal and Heavy Duty ratings are available for this drive
 (2) When the drive is controlling motors with lower amp ratings, refer to the drive nameplate for drive input current rating.
 (3) The AIC ratings of the Bulletin 140M Motor Protector Circuit Breakers may vary. See the Use of Motor Protection Circuit Breakers with Variable-Frequency Drives Application Techniques, publication 140M-AI002.
 (4) Bulletin 140M with adjustable current range should have the current trip set to the minimum range that the device will not trip.
 (5) Manual Self-Protected (Type E) Combination Motor Controller, UL Listed for 480V/277 and 600V/347 AC input. Not UL Listed for use on 480V or 600V Delta/Delta, corner ground, or high-resistance ground systems.
 (6) When used with the 140M circuit breaker, the 25A-E9P9N104 must be installed in a ventilated or non-ventilated enclosure with the minimum size of 457.2 x 457.2 x 269.8 mm (18 x 18 x 10.62 in.).
 (7) When using a Manual Self-Protected (Type E) Combination Motor Controller with this drive power rating, the drive must be installed in a ventilated or non-ventilated enclosure with the minimum volume specified in this column. Application specific thermal considerations may require a larger enclosure.
 (8) Circuit breaker selection is not available for this drive rating.